

Service Manual

Cassette Deck
RS-M24
 (Silver Face)
 (Black Face)

Metal Tape-Compatible Cassette Deck with
 Soft Touch Operation and FL-Meter with Peak Hold

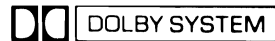

This is the Service Manual for the following areas.

- B** For United Kingdom.
- N** For Asia, Latin America, Middle East and Africa areas.
- A** For Australia.
- F** For Asian PX.
- L** For European PX.

RS-M24 MECHANISM SERIES

Specifications

Track system:	4-track 2-channel stereo recording and playback	Outputs:	LINE: output level 700mV, output impedance 1.5k Ω or less, load impedance 22k Ω over
Tape speed:	4.8cm/s (1-7/8 ips.)		HEADPHONE: output level 80—350mV, load impedance 8—125 Ω
Wow and flutter:	0.05% (WRMS), \pm 0.14% (DIN)	Rec./Pb connection:	5P DIN type;
Frequency response: Metal tape;	20—18,000Hz		input sensitivity 0.25mV, impedance 5.9k Ω
	30—17,000Hz (DIN)		output level 700mV, impedance 5.2k Ω
CrO ₂ /Fe-Cr tape;	20—18,000Hz	Bias frequency:	90kHz
	30—16,000Hz \pm 3dB	Motor:	Electrical DC governor motor
Normal tape:	20—17,000Hz	Heads:	2-head system;
	30—15,000Hz (DIN)		1-MX head for record/playback
	30—14,000Hz \pm 3dB		1-sensidust/ferrite double-gap head for erasure
Signal-to-noise ratio: Dolby NR in;	67dB (above 5kHz)	Power requirements:	AC; 110/125/220/240V, 50-60Hz
Dolby NR out;	57dB (signal level=max. recording level, Fe-Cr/CrO ₂ type tape)	Preset power voltage:	125V (for Asian PX.)
Fast forward and			220V (for European PX.)
rewind time:	Approx. 90 seconds with C-60 cassette tape		240V (for United Kingdom.)
Inputs:	MIC; sensitivity 0.25mV, input impedance 46k Ω for United Kingdom and Australia.	Power consumption:	28W (for United Kingdom and Australia.)
	35k Ω for Asia, Latin America, Middle East, Africa areas and PX.		14W (for Asia, Latin America, Middle East, Africa areas and PX.)
	applicable microphone impedance 400 Ω —10k Ω	Dimensions:	43.0cm(W) \times 11.9cm(H) \times 28.2cm(D)
LINE; sensitivity 60mV, input impedance 40k Ω		Weight:	[16-7/8"(W) \times 4-3/4"(H) \times 11-1/8"(D)]
			5kg (11 lbs)

Specifications are subject to change without notice.

* 'Dolby' and the double-D symbol are trademarks of Dolby Laboratories.

Technics

Panasonic Tokyo
 Matsushita Electric Industrial Co., Ltd.
 1-7-15, 6-chome, Shibuya-ku, Minato-ku, Tokyo 105 Japan

Matsushita Electric Trading Co., Ltd.
 P.O. Box 288, Central Osaka Japan

CONTENTS

ITEM	PAGE	ITEM	PAGE
LOCATION OF CONTROLS AND COMPONENTS	1	ADJUSTMENT PARTS LOCATION	8
DISASSEMBLY INSTRUCTIONS	2	ELECTRICAL PARTS LOCATION	8
ASSEMBLY INSTRUCTIONS	3	SCHEMATIC DIAGRAM	9
OPERATING PRINCIPLE OF REMOTE CONTROL	4	CIRCUIT BOARD	10
MEASUREMENT AND ADJUSTMENT METHODS	5	WIRING CONNECTION DIAGRAM	11
		EXPLODED VIEWS	12
		CABINET PARTS	13

LOCATION OF CONTROLS AND COMPONENTS

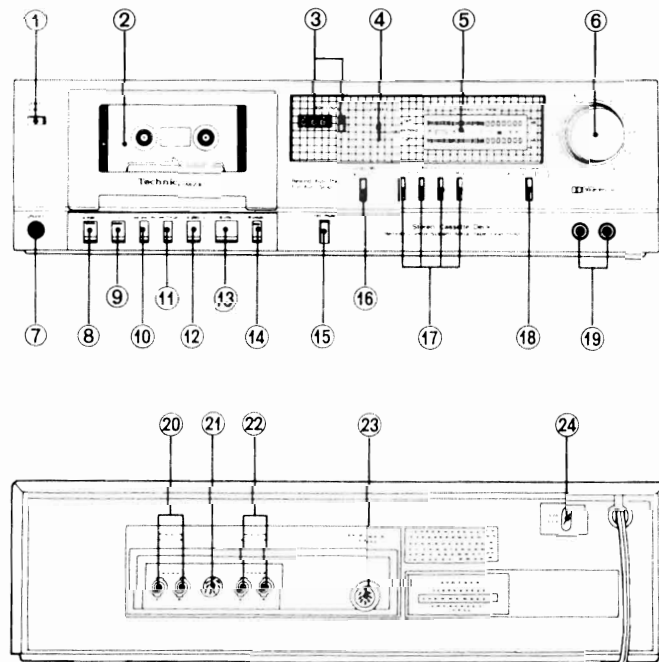

Fig. 1

- | | |
|--|--|
| ① Power switch (power) | ⑬ Stop button (■ stop) |
| ② Cassette holder | ⑭ Pause button (pause) |
| ③ Tape counter and Reset button (tape counter) | ⑮ Record-muting button (rec mute) |
| ④ Record indication lamp (record) | ⑯ Dolby noise-reduction switch (Dolby NR) |
| ⑤ FL (fluorescent level) meters | ⑰ Tape selector (tape select-normal/Fe-Cr/CrO ₂ /Metal) |
| ⑥ Input level controls (input level) (L → R) | ⑱ Input selector (input select) |
| ⑦ Headphones jack (phones) | ⑲ Microphone jacks (L mic R) |
| ⑧ Eject button (▲ eject) | ⑳ Line output jacks (LINE OUT) (R·L) |
| ⑨ Record button (○ rec) | ㉑ Record/Playback connection socket (REC/PLAY) |
| ⑩ Rewind/Review button (◀◀ rew/rev) | ㉒ Line input jacks (LINE IN) (R·L) |
| ⑪ Fast forward/Cue button (▶▶ ff/cue) | ㉓ Remote-control connector (REMOTE CONTROL) |
| ⑫ Play button (▶ play) | ㉔ Voltage selector (VOLTAGE SELECTOR) |

DISASSEMBLY NOTE:

MECHANISM SECTION

1. For repair, measurement or adjustment with the mechanism removed from the unit be sure to ground the lower base plate of the mechanism.
2. For grounding, connect a extension cord to the mechanism's lower base plate and the lug terminal from amplifier printed circuit board.
3. Without grounding, the amplifier does not operate properly.

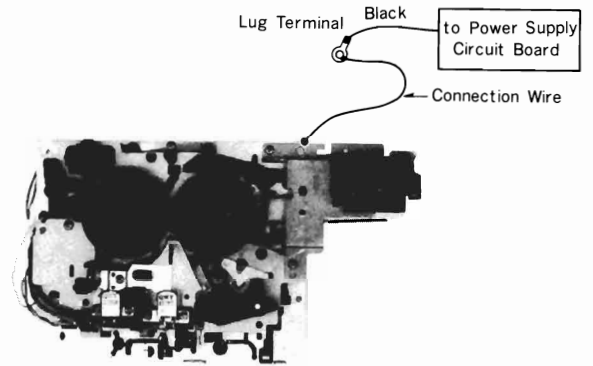

Fig. 7

ASSEMBLY INSTRUCTIONS

• Belt mounting

Check that each belt is free of damage or grease on the surface, after that, set the belt as illustrated, and mount it on the lower base plate (QXK2276) after setting the takeup belt (QDB0274) on the fast forward belt pulley (QXP0607).

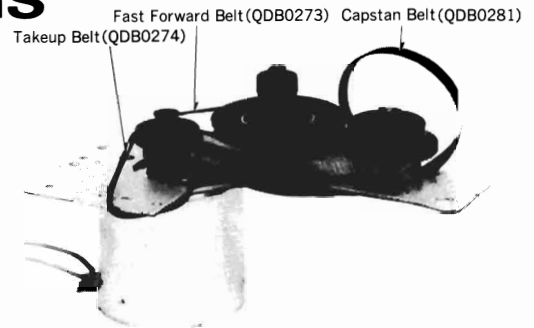

Fig. 8

• Positioning the Takeup Reel Table Assembly

When installing the takeup reel table assembly, be sure to mount the auto-stop friction hub (shown in Fig. 9-b.), as illustrated in Fig. 9-a. If the takeup reel table is positioned incorrectly at any place other than that shown in Fig. 9-a, the auto-stop mechanism remains operative at all times.

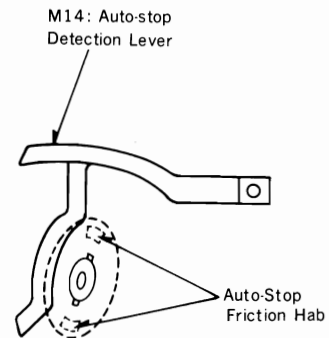

Fig. 9-a

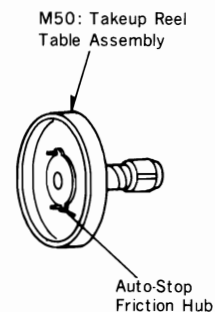
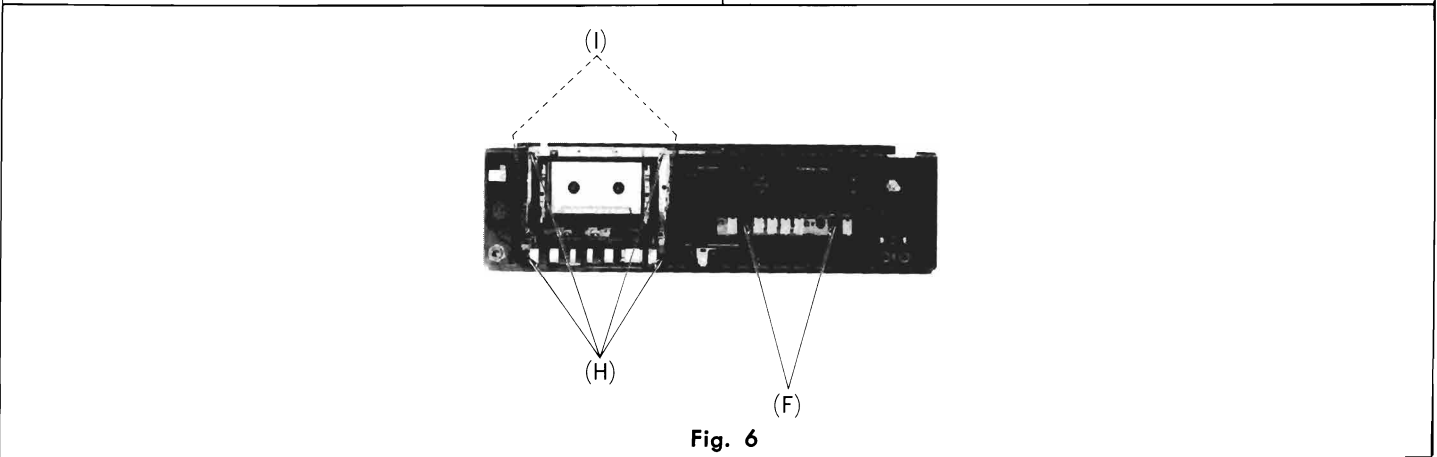
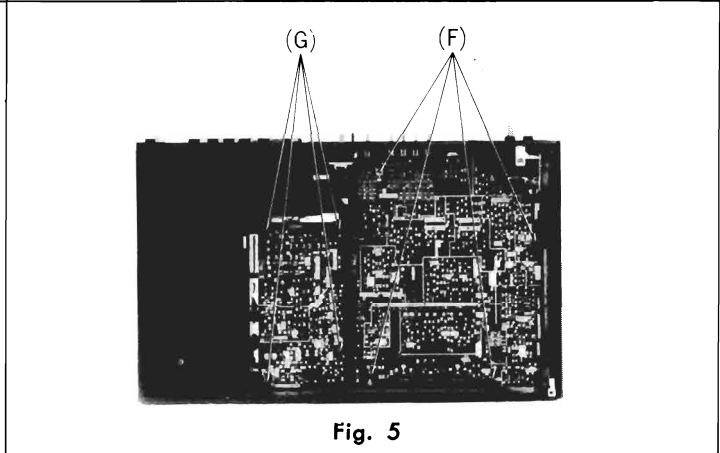
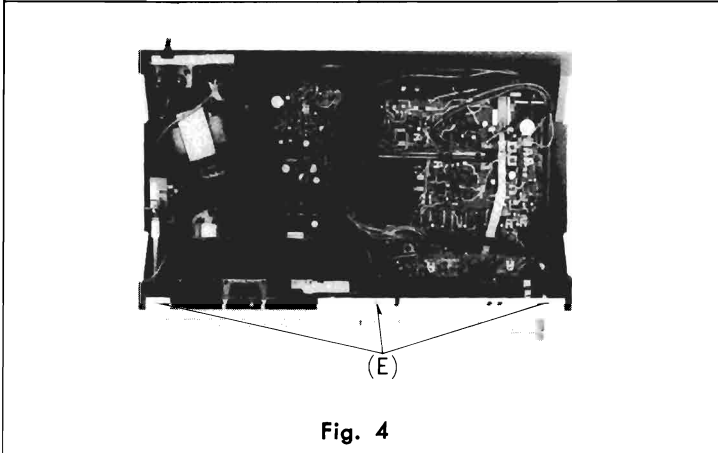
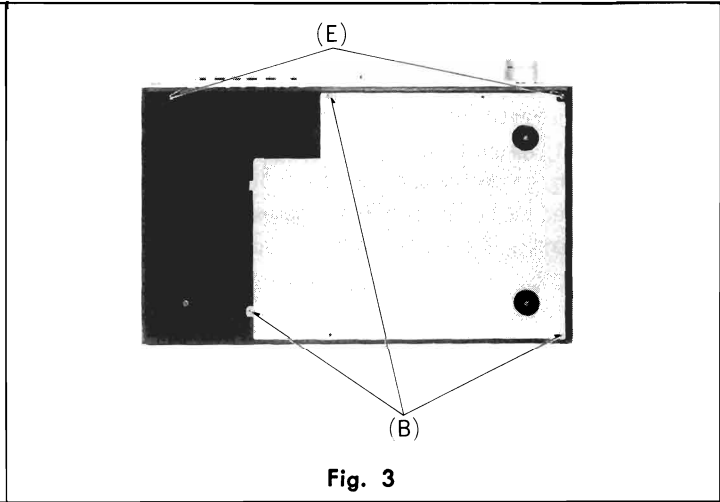
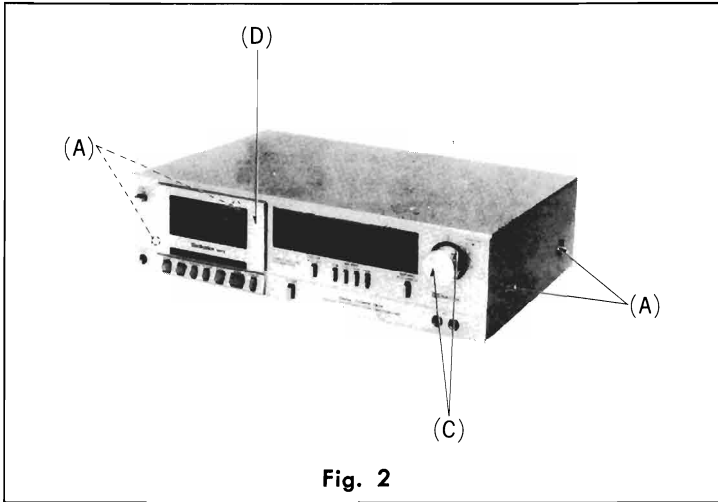

Fig. 9-b

DISASSEMBLY INSTRUCTIONS



Procedure	To remove ——— .	Remove ——— .	Shown in fig. ——— .
1	Case cover	• 4 screws (A)	2
1	Bottom cover	• 3 screws (B)	3
2	Front panel	• Control knob (C) • Cassette lid (D) • 5 screws (E)	2 2 3, 4
2	Main circuit board	• 6 red screws (F)	5, 6
2	Power supply circuit board	• 4 red screws (G)	5
3	Mechanism	• 4 screws (H)	6
4	Operation button assembly and cassette holder	• 2 screws (I)	6

• Mounting the Operation Button Assembly

Before mounting the operation button assembly on the mechanism body, be sure to lift the main control lever in the direction of the arrow using a screwdriver, as shown in Fig. 9-c, until it locks in place. If it is not mounted in this manner, the hub of the playback button assembly during playback catches on the main control lever, making it impossible to release playback mode.

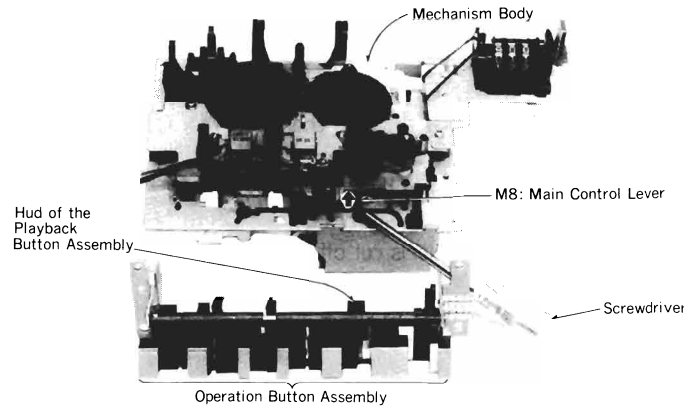
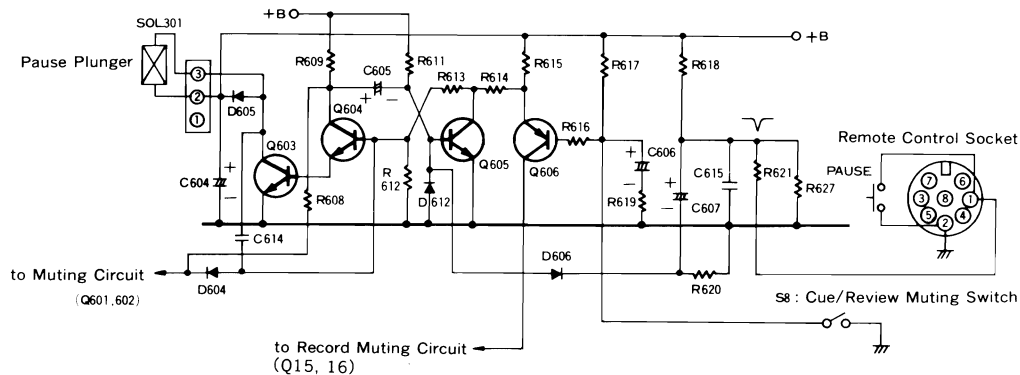

Fig. 9-c

OPERATING PRINCIPLE OF REMOTE CONTROL

Pause mode



1. In record and playback mode, Q604 is OFF and Q605 is ON in the monostable multivibrator circuit.
2. When the pause button on the remote control unit is pressed and a negative pulse is momentarily applied to R621 through socket 1.
3. C607 starts discharging, causing the base potential of Q605 to decrease, and Q605 is turned OFF and Q604 ON (Both Q605 and Q604 are inverted). This causes C605 to discharge.
4. Q604 is ON, causing Q603 to be ON, whereby pause plunger is attracted to change the pause mechanism to a lock condition.
5. Base potential of Q605 increases afterward, causing Q605 to be ON and Q604 OFF, and Q603 also OFF, and the attraction of pause plunger is released. Even when the pause plunger is released, the pause mechanism is locked and remains paused.
6. For pause release, when the pause button on the remote control unit is pressed again to repeat operations 1 — 4 causing pause plunger to refunction, thus releasing locked pause. After that, operation of 5 is effected, causing the pause plunger to return to its original condition.

REC MUTE mode

1. When REC MUTE button on the remote control unit is pressed, base bias of Q17 becomes (L) for Q17 to be OFF while the button remains pressed.
2. Q17 is OFF, causing the collector to become (H), and recording muting, transistors Q7 and Q8 to be ON, whereby the recording signal is cut off.

NOTE:

- (H) : High Potential
- (L) : Low Potential

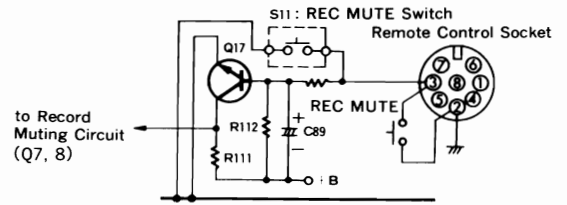



MEASUREMENT AND ADJUSTMENT METHODS

NOTES: Keep good condition, set lever switches and controls in the following positions, unless otherwise specified.

- Make sure heads are clean.
- Make sure capstan and pressure roller are clean.
- Judgeable room temperature: $20 \pm 5^\circ\text{C}$ ($68 \pm 9^\circ\text{F}$)
- Dolby NR switch: OUT
- Tape selector: Normal position
- Input selector: Line in
- Input level control: Maximum

ITEM	MEASUREMENT & ADJUSTMENT
<p>A Head position adjustment</p> <p>Condition: * Playback and pause mode</p>	<p>(The head adjusting plate is provided to adjust the tape touch of the head in cue or review mode.)</p> <ol style="list-style-type: none"> 1. Press the playback button and pause button. 2. Measure the space between the pinch roller and the capstan. <div style="border: 1px solid black; padding: 5px; width: fit-content; margin: 10px auto;"> <p style="text-align: center;">Standard value: $0.5 \pm 0.3\text{cm}$</p> </div> <ol style="list-style-type: none"> 3. If the measured value is not within the standard value, untighten screw (A), and slide the head adjusting plate in the direction of arrow (B) for adjustment. <p style="text-align: right;">Fig. 10</p>
<p>B Head azimuth adjustment</p> <p>Condition: * Playback mode</p> <p>Equipment: * VTVM * Oscilloscope * Test tape (azimuth) ... QZZCFM</p>	<ol style="list-style-type: none"> 1. Test equipment connection is shown in fig. 11. 2. Playback azimuth tape (QZZCFM 8kHz). 3. Adjust record/playback head angle adjustment screw (B) in fig. 12 so that output level at LINE OUT becomes maximum. 4. Measure both channels, and adjust levels for equal output. 5. After adjustment lock head adjustment screw with lacquer. <p style="text-align: right;">Fig. 11 Fig. 12</p>
<p>C Tape speed</p> <p>Condition: * Playback mode</p> <p>Equipment: * Digital electronic counter or frequency counter * Test tape ... QZZCWAT</p>	<p>Tape speed accuracy</p> <ol style="list-style-type: none"> 1. Test equipment connection is shown in fig. 13. 2. Playback test tape (QZZCWAT 3,000Hz), and supply playback signal to frequency counter. 3. Measure this frequency. 4. On the basis of 3,000Hz, determine value by following formula: $\text{Tape speed accuracy} = \frac{f - 3,000}{3,000} \times 100 (\%) \quad \text{where, } f = \text{measured value}$ <ol style="list-style-type: none"> 5. Take measurement at middle section of tape. <div style="border: 1px solid black; padding: 5px; width: fit-content; margin: 10px auto;"> <p style="text-align: center;">Standard value: $\pm 1.5\%$</p> </div> <p style="text-align: right;">Fig. 13</p>

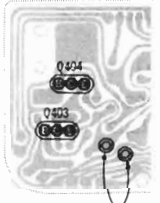
ITEM	MEASUREMENT & ADJUSTMENT
	<p>Adjustment method</p> <ol style="list-style-type: none"> 1. Playback the test tape (middle). 2. Adjust so that frequency becomes 3,000Hz. 3. Tape speed adjustment VR shown in fig. 27. <p>Tape speed fluctuation</p> <p>Make measurements in same manner as above (beginning, middle and end of tape), and determine the difference between maximum and minimum values and calculate as follows:</p> $\text{Tape speed fluctuation} = \frac{f_1 - f_2}{3,000} \times 100 (\%) \quad f_1 = \text{maximum value, } f_2 = \text{minimum value}$ <div style="border: 1px solid black; padding: 5px; width: fit-content; margin: 10px auto;"> <p>Standard value: 1%</p> </div>
<p>㊦ Playback frequency response</p> <p>Condition:</p> <ul style="list-style-type: none"> * Playback mode <p>Equipment:</p> <ul style="list-style-type: none"> * VTVM * Oscilloscope * Test tape ... QZZCFM 	<ol style="list-style-type: none"> 1. Test equipment connection is as same as "Head azimuth adjustment" but use the test tape instead of head azimuth tape (See fig. 11). 2. Place UNIT into playback mode. 3. Playback frequency response test tape. 4. Measure output level at 12.5kHz, 10kHz, 8kHz, 4kHz, 1kHz, 315Hz, 250Hz, 125Hz and 63Hz, and compare each output level with standard frequency 315Hz, at LINE OUT. 5. Make measurement for both channels. 6. Make sure that the measured value is within the range specified in the frequency response chart. <div style="text-align: center;"> <p>Playback frequency response chart</p> <p>Fig. 14</p> </div>
<p>㊦ Playback gain</p> <p>Condition:</p> <ul style="list-style-type: none"> * Playback mode <p>Equipment:</p> <ul style="list-style-type: none"> * VTVM * Oscilloscope * Test tape ... QZZCFM 	<ol style="list-style-type: none"> 1. Test equipment connection is shown in fig. 11. 2. Playback standard recording level portion on test tape (QZZCFM 315Hz), and using VTVM measure the output level at LINE OUT jack. 3. Make measurement for both channels. <div style="border: 1px solid black; padding: 5px; width: fit-content; margin: 10px auto;"> <p>Standard value: around 0.7V</p> </div> <p>Adjustment</p> <ol style="list-style-type: none"> 1. If measured value is not standard, adjust VR3 (L-CH), VR4 (R-CH) (See fig. 27 on page 8). 2. After adjustment, check "Playback frequency response" again.
<p>㊦ Bias leak</p> <p>Condition:</p> <ul style="list-style-type: none"> * Record mode <p>Equipment:</p> <ul style="list-style-type: none"> * VTVM * Oscilloscope 	<ol style="list-style-type: none"> 1. Test equipment connection is shown in fig. 15. 2. Place UNIT into record mode. 3. Adjust trap coil L3 (L-CH), L4 (R-CH) so that measured value on VTVM becomes minimum. 4. Take adjustment for both channels. <div style="text-align: center;"> <p>Fig. 15</p> </div>
<p>㊦ Erase current</p> <p>Condition:</p> <ul style="list-style-type: none"> * Record mode * Tape selector <ul style="list-style-type: none"> ... Metal position ... CrO₂ position ... Fe-Cr position ... Normal position <p>Equipment:</p> <ul style="list-style-type: none"> * VTVM * Oscilloscope 	<ol style="list-style-type: none"> 1. Test equipment connection is shown in fig. 16. 2. Press the record and pause buttons. 3. Set the tape selector to metal position. 4. Read voltage on VTVM and calculate erase current by following formula: $\text{Erase current (A)} = \frac{\text{Voltage across both ends of R301}}{1 (\Omega)}$ <div style="border: 1px solid black; padding: 5px; width: fit-content; margin: 10px auto;"> <p>Standard value: 110±10mA (Metal position)</p> </div> <ol style="list-style-type: none"> 5. If measured value is not within standard, adjust VR301. 6. Set the tape selector to each position. 7. Make sure that the measured value is within standard. <div style="border: 1px solid black; padding: 5px; width: fit-content; margin: 10px auto;"> <p>Standard value: around 65mA (CrO₂ position), around 55mA (Fe-Cr position), around 50mA (Normal position)</p> </div> <div style="text-align: center;"> <p>Fig. 16</p> </div>

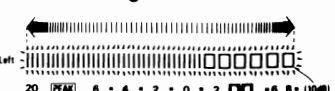
ITEM	MEASUREMENT & ADJUSTMENT
<p>⊕ Bias current</p> <p>Condition:</p> <ul style="list-style-type: none"> • Record mode • Tape selector <ul style="list-style-type: none"> ... Metal position ... Normal position ... Fe-Cr position ... CrO₂ position <p>Equipment:</p> <ul style="list-style-type: none"> • VTVM • Oscilloscope 	<p>A. Measurement and adjustment for metal position.</p> <ol style="list-style-type: none"> 1. Test equipment connection is shown in fig. 17. 2. Press the record and pause buttons. 3. Set the tape selector to metal position. 4. Read voltage on VTVM and calculate bias current by following formula: <div style="text-align: center;"> $\text{Bias current (A)} = \frac{\text{Value read on VTVM (V)}}{10 (\Omega)}$ </div> <div style="border: 1px solid black; padding: 5px; margin: 10px auto; width: fit-content;"> <p>Standard value: 800 ± 20 μA (Metal position)</p> </div> <ol style="list-style-type: none"> 5. If measured value is not within standard, adjust VR303 (L-CH), VR304 (R-CH). <p>B. Measurement and adjustment for normal position.</p> <ol style="list-style-type: none"> 1. Change the tape selector to normal position. 2. Make sure that the measured value is within standard. <div style="border: 1px solid black; padding: 5px; margin: 10px auto; width: fit-content;"> <p>Standard value: around 370 μA (Normal position)</p> </div> <ol style="list-style-type: none"> 3. If measured value is not within standard, adjust VR302 (L-CH), VR304 (R-CH). <p>C. Measurement for Fe-Cr and CrO₂ position.</p> <ol style="list-style-type: none"> 1. Set the tape selector to each position. 2. Make sure that the measured value is within standard. <div style="border: 1px solid black; padding: 5px; margin: 10px auto; width: fit-content;"> <p>Standard value: around 390 μA (Fe-Cr position), around 500 μA (CrO₂ position)</p> </div>
<p>① Fluorescent meter</p> <p>Condition:</p> <ul style="list-style-type: none"> • Record mode • Input level control ... MAX • Tape selector <ul style="list-style-type: none"> ... Normal position <p>Equipment:</p> <ul style="list-style-type: none"> • VTVM • AF oscillator • ATT 	<ol style="list-style-type: none"> 1. Test equipment connection is shown in fig. 22. 2. As shown in fig. 18, connecting the collector and ground of Q21 stops the oscillation of the astable multivibrator comprising Q403 and Q404. 3. Supply 1kHz signal (-24 dB) to the LINE IN jack, then press the record and pause buttons. 4. Adjust the ATT so that the output level at LINE OUT jack becomes 0.7V (Then input level at this condition is termed the standard input level). 5. Adjustment at "-20 dB": <ol style="list-style-type: none"> A. Adjust the ATT so that input level is -20 dB below standard recording level. B. Adjust VR401 so that the -20 dB segment lights up in the -20 ± 0.8 dB range (L-CH only) (See fig. 19). 6. Adjustment at "0 dB": <ol style="list-style-type: none"> A. Adjust the ATT so that the output level at LINE OUT jack becomes 0.7V (= standard input level). B. Adjust VR402 so that the +1 dB segment lights up in the 0 ± 0.2 dB range of the standard input level (See fig. 20). 7. Repeat twice between steps 5 and 6 above. 8. Adjust ATT and check that all segments light up when an input signal level is increased to 10 dB higher than the standard input level (See fig. 21). <div style="text-align: right;"> <p>FL METER CIRCUIT BOARD</p>  <p>PEAK HOLD OFF Fig. 18</p> </div> <div style="text-align: right;">  <p>Fig. 19</p>  <p>Fig. 20</p>  <p>Fig. 21</p> </div>
<p>⊙ Dolby NR circuit</p> <p>Condition:</p> <ul style="list-style-type: none"> • Record mode • Input level control ... MAX <p>Equipment:</p> <ul style="list-style-type: none"> • VTVM • AF oscillator • ATT • Oscilloscope 	<ol style="list-style-type: none"> 1. Place UNIT into record mode, set the Dolby NR switch to OUT position and supply to LINE IN to obtain -34.5 dB at TP9 (L-CH), TP10 (R-CH) (frequency 5 kHz). 2. Confirm that the value at IN position is 8 (± 2.5) dB greater than the value at OUT position of Dolby NR switch.

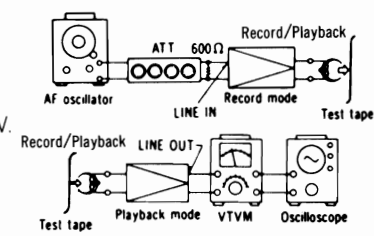
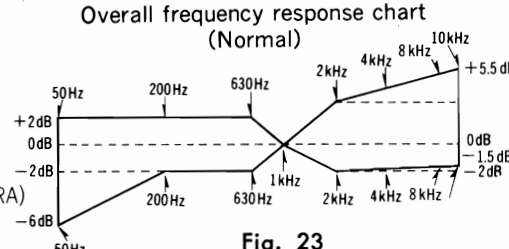
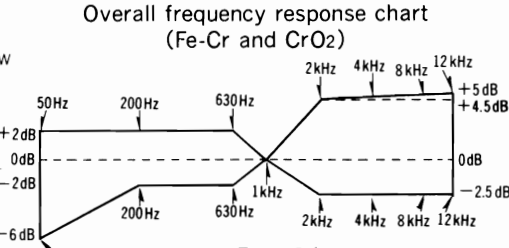
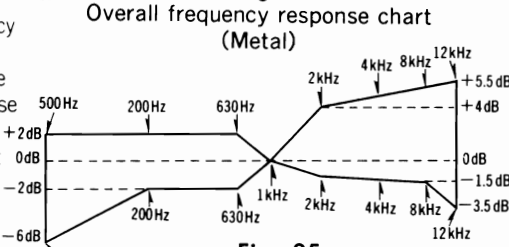
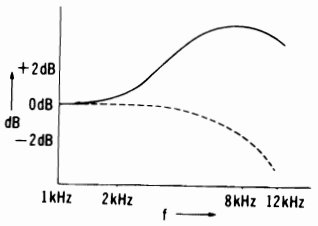
ITEM	MEASUREMENT & ADJUSTMENT
<p>K Overall gain</p> <p>Condition:</p> <ul style="list-style-type: none"> Record/playback mode Tape selector <ul style="list-style-type: none"> Normal position Input level control ... MAX Standard input level; <ul style="list-style-type: none"> MIC..... -72 ± 4 dB LINE IN..... -24 ± 4 dB <p>Equipment:</p> <ul style="list-style-type: none"> VTVM ATT Test tape (reference blank tape) <ul style="list-style-type: none"> QZZCRA for Normal 	<ol style="list-style-type: none"> Test equipment connection is shown in fig. 22. Place UNIT into record mode, and tape selector to normal position. Supply 1kHz signal (-24 dB) from AF oscillator, through ATT to LINE IN. Adjust ATT until monitor level at LINE OUT becomes 0.7 V. Using test tape, make recording. Playback recorded tape, and make sure the value at LINE OUT on VTVM becomes 0.7 V. If measured value is not 0.7V, adjust VR5 (L-CH), VR6 (R-CH) (See fig. 27 on page 8). Repeat from step 2.  <p style="text-align: center;">Fig. 22</p>
<p>L Overall frequency response</p> <p>Condition:</p> <ul style="list-style-type: none"> Record/playback mode Input level control ... MAX Tape selector <ul style="list-style-type: none"> Normal position Fe-Cr position CrO₂ position Metal position <p>Equipment:</p> <ul style="list-style-type: none"> VTVM AF oscillator ATT Test tape (reference blank tape) <ul style="list-style-type: none"> QZZCRA for Normal QZZCRY for Fe-Cr QZZCRX for CrO₂ QZZCRZ for Metal 	<p>Note:</p> <p>Before measuring and adjusting make sure of the playback frequency response. (For the method of measurement, please refer to the playback frequency response.)</p> <ol style="list-style-type: none"> Test equipment connection is shown in fig. 22. Load reference blank normal test tape (QZZCRA) and place UNIT into record mode. Set the tape selector to normal position. Supply 1kHz signal from AF oscillator through ATT to LINE IN. Adjust ATT so that input level is -20 dB below standard recording level (standard recording level -24 dB). At this time, LINE OUT level indicates 0.07 V. Record each frequency 50Hz, 100Hz, 200Hz, 1kHz, 2kHz, 4kHz, 8kHz and 10kHz (12kHz for CrO₂, Fe-Cr and Metal tape) at the same level. Playback and express in dB the difference the between playback output level of each frequency based on playback output level of 1kHz. Make sure that the measured value is within the range specified in the overall frequency response chart for normal tape shown in fig. 23. If measured value is not within standard, adjust bias current. <ul style="list-style-type: none"> VR302 L-CH, VR304 R-CH <p>Note:</p> <ul style="list-style-type: none"> L-CH adjustment is made as much as by using VR302. For further L-CH adjustment, use VR303. When the frequency response between the middle and high frequency range becomes higher than the standard value, as shown by the solid line in fig. 26 increase, refer to bias current adjustment. When it becomes lower, as shown by dotted line, refer to bias current adjustment. (For the method of bias current measurement, refer to "Bias current adjustment" on page 5.) <ol style="list-style-type: none"> Repeat from step 2. Change test tape to Fe-Cr (QZZCRY), CrO₂ (QZZCRX) and Metal (QZZCRZ). Set the tape selector to each position. Measure as same as manner above. Make sure that the measured value is within the range specified in the overall frequency response chart for Fe-Cr, CrO₂ and Metal tape shown in fig. 24 and fig. 25.  <p style="text-align: center;">Fig. 23</p>  <p style="text-align: center;">Fig. 24</p>  <p style="text-align: center;">Fig. 25</p>  <p style="text-align: center;">Fig. 26</p>

ADJUSTMENT PARTS LOCATION

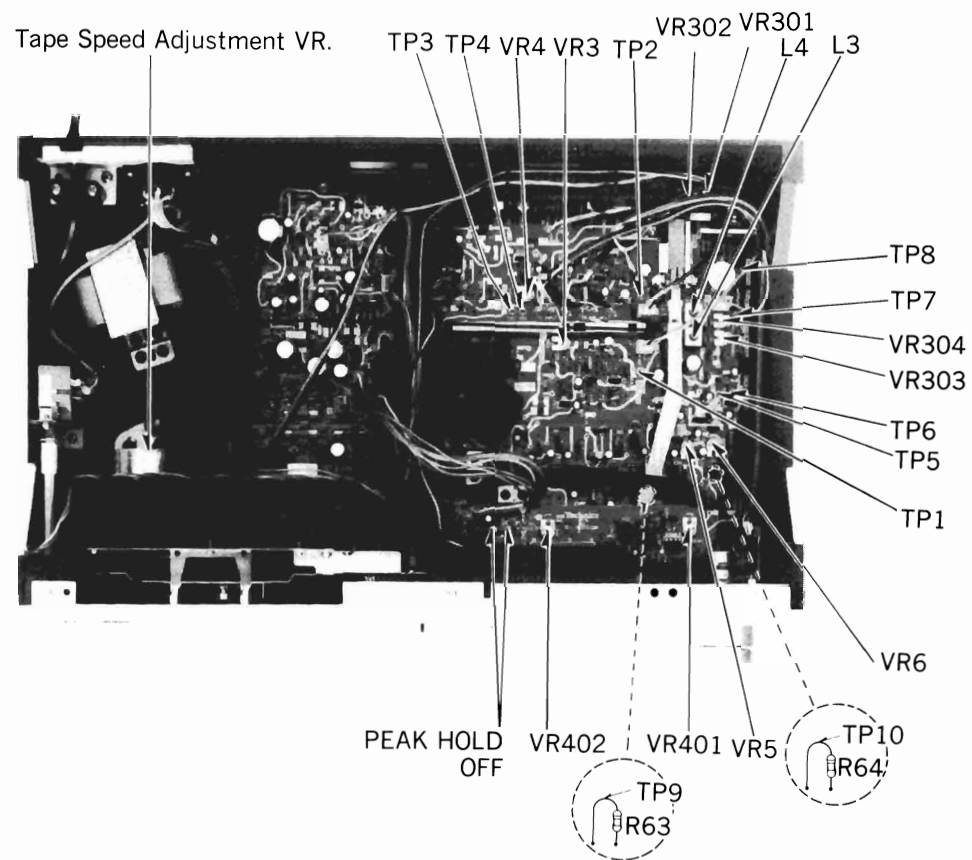
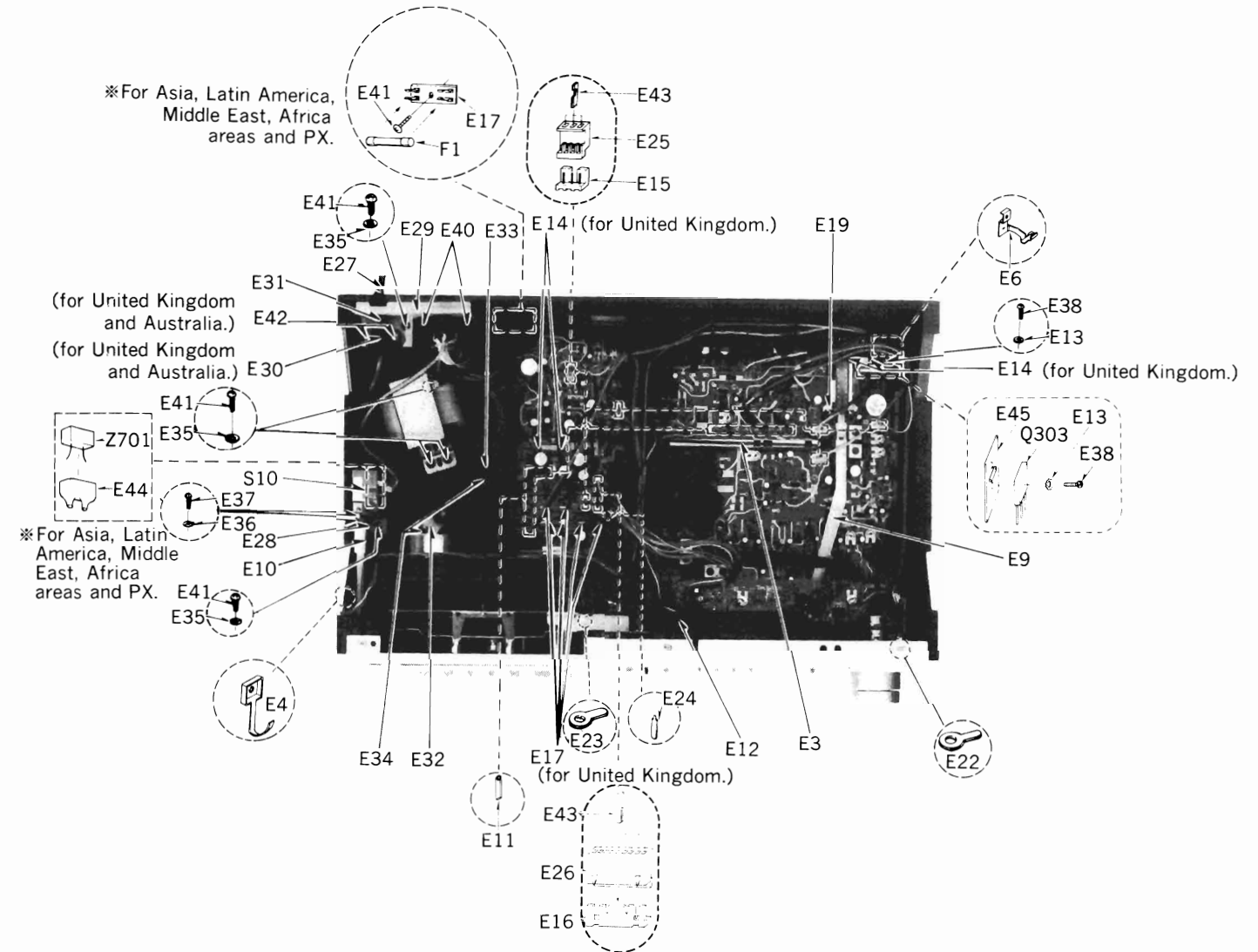
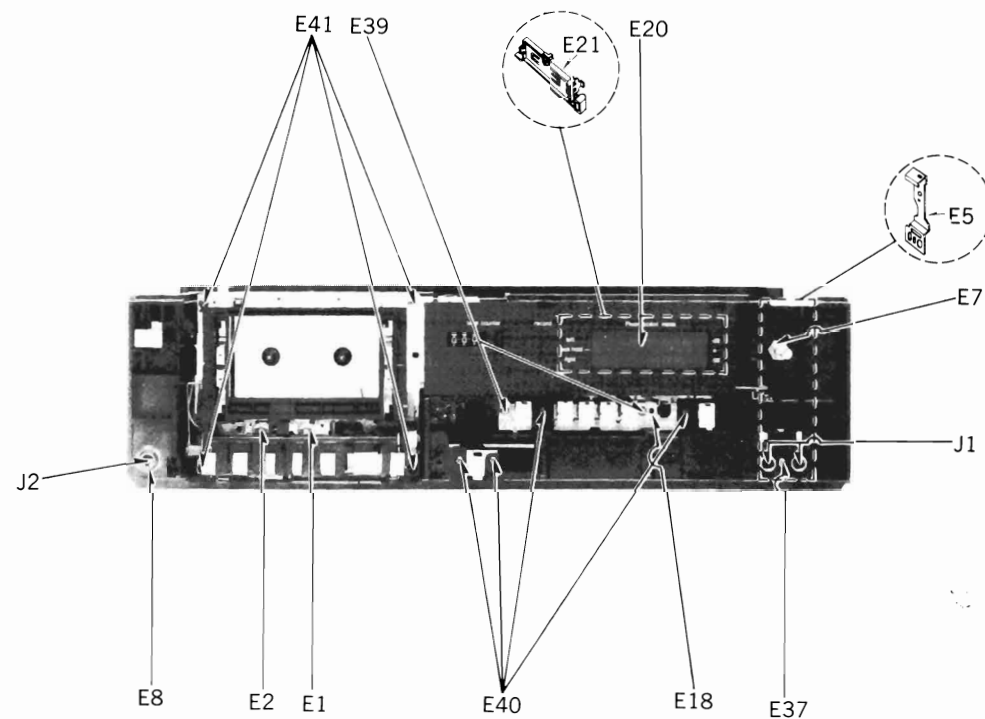

Fig. 27

ELECTRICAL PARTS LOCATION



NOTE: Δ indicates that only parts specified by the manufacturer be used for safety.

Ref. No.	Part No.	Part Name & Description	Ref. No.	Part No.	Part Name & Description	Ref. No.	Part No.	Part Name & Description
ELECTRICAL PARTS								
E1	QWY4122Z	Record/Playback Head	E18	QMA3881	Switch Angle-A	E32	QML3611	Recording Lever-A
E2	QWY2133Z	Erase Head	E19	QMA3880	Switch Angle-B	E33	QML3612	Recording Lever-B
E3	QBS1127	Recording Wire	E20	QSIFL001F	FL Meter	E34	XUB5FT	Stop Ring 5 ϕ
E4	QJC0026	Earth Plate-A	E21	QKJ0391	Level Meter Holder	E35	XWA38	Washer
E5	QJC0027	Earth Plate-B	E22	QJT1022	Lug Terminal	E36	XWA26B	"
E6	QJC0028	Earth Plate-C	E23	QJT0015	"	E37	XSN3+6S	Screw +3 \times 6
E7	QNJ1039	Nut 9 ϕ	E24	QJT0055	Connector Terminal	E38	XSN26+8	Screw +2.6 \times 8
E8	QNJ1070	Nut 12 ϕ	E25	QJS1921TN	3 Pin Socket	E39	XTN3+6B	Tapping Screw +3 \times 6
E9	QMR1828	Switch Rod-A	E26	QJS1923TN	9 Pin Socket	E40	XTN3+8B	Tapping Screw +3 \times 8
E10	QMR1829	Switch Rod-B	E27	Δ QFC1205M	AC Power Cord	E41	XTN3+10B	Tapping Screw +3 \times 10
E11	QJT1041	Check Pin	E28	Δ QFC1203M	"	E42	XTN3+25B	Tapping Screw +3 \times 25
E12	XAMQ23P300N	Pilot Lamp	E29	Δ QFC1208M	"	*For United Kingdom and Australia.		
E13	XWG26	Washer	E30	Δ QMA3882	Switch Angle-C	E43	QJT1054	Contact
E14	Δ QZE0003	Porcelain Tube	E31	QMA3879	Power Switch Angle	E44	QTW1118	Spark Killer Cover
E15	QJP1921TN	3 Pin Post	E32	QTD1164	Cord Clamper	E45	QTH1118	Heat Sink
E16	QJP1923TN	9 Pin Post	*For United Kingdom and Australia.			*For Asia, Latin America, Middle East, Africa areas and PX.		
E17	Δ QTF1054	Fuse Holder	E33	QBJ1425	Cord Bushing	*For United Kingdom and Australia.		
*For United Kingdom.			E34	QTD1129	"	*For Asia, Latin America, Middle East, Africa areas and PX.		
Δ QTF1049								
*For Asia, Latin America, Middle East, Africa areas and PX.								

SCHEMATIC DIAGRAM

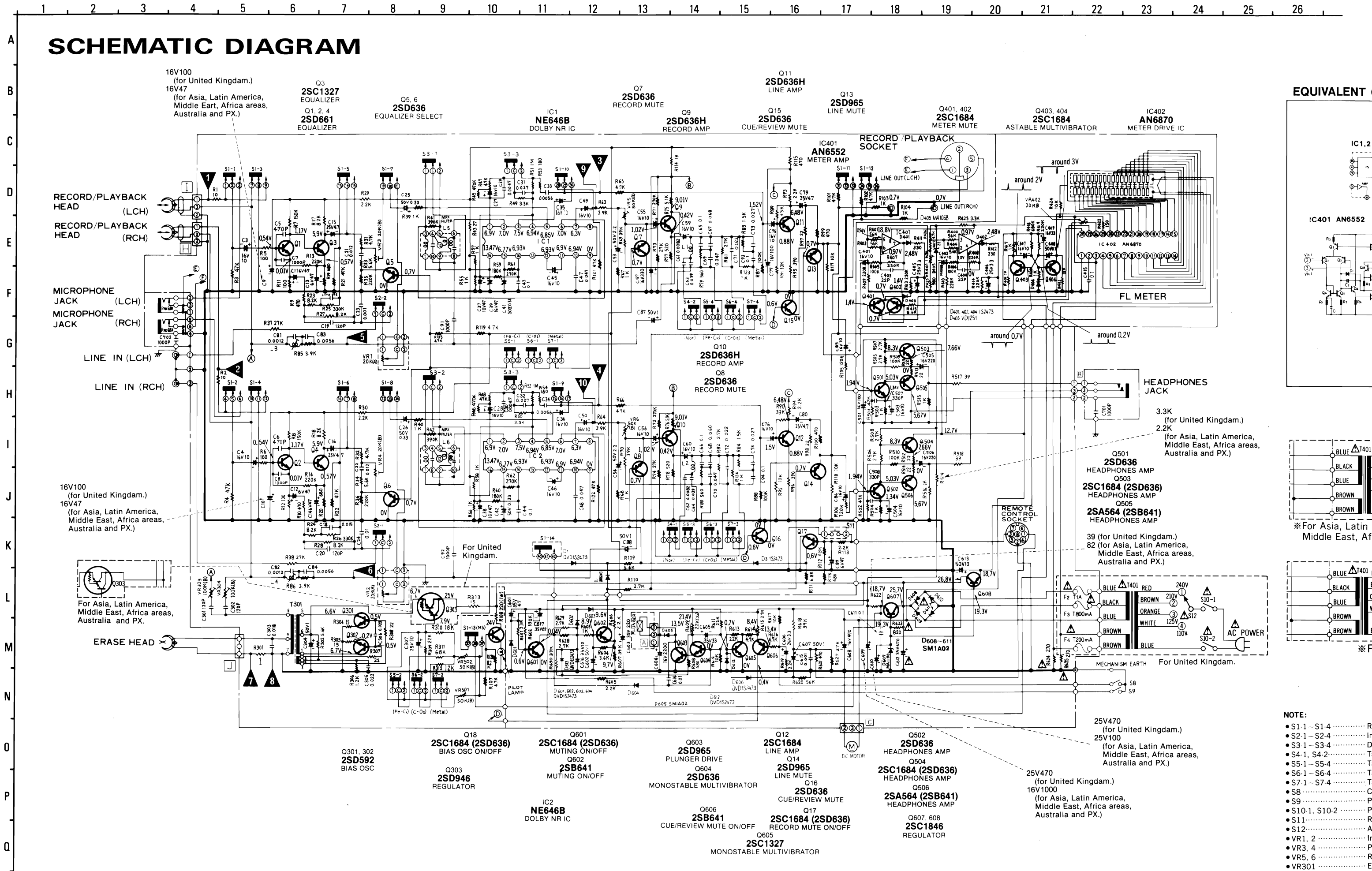

EQUIVALENT CIRCUIT

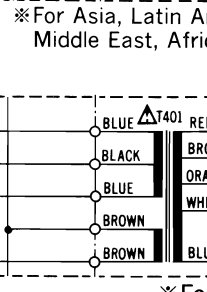
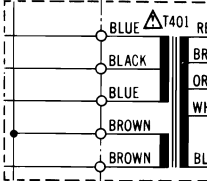
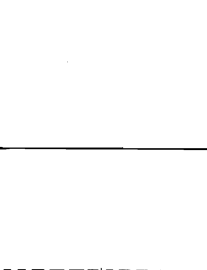
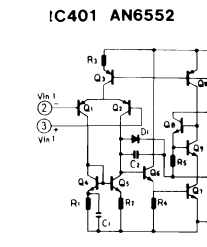
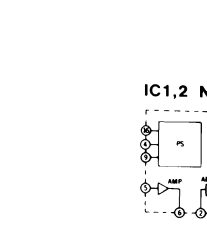

- NOTE:**
- S1-1 - S1-4 Reco
 - S2-1 - S2-4 Input
 - S3-1 - S3-4 Dolby
 - S4-1, S4-2 Tape
 - S5-1 - S5-4 Tape
 - S6-1 - S6-4 Tape
 - S7-1 - S7-4 Tape
 - S8 Cue
 - S9 Play
 - S10-1, S10-2 Powe
 - S11 Reco
 - S12 AC p
 - VR1, 2 Input
 - VR3, 4 Play
 - VR5, 6 Reco
 - VR301 Erase
 - VR302 Bias

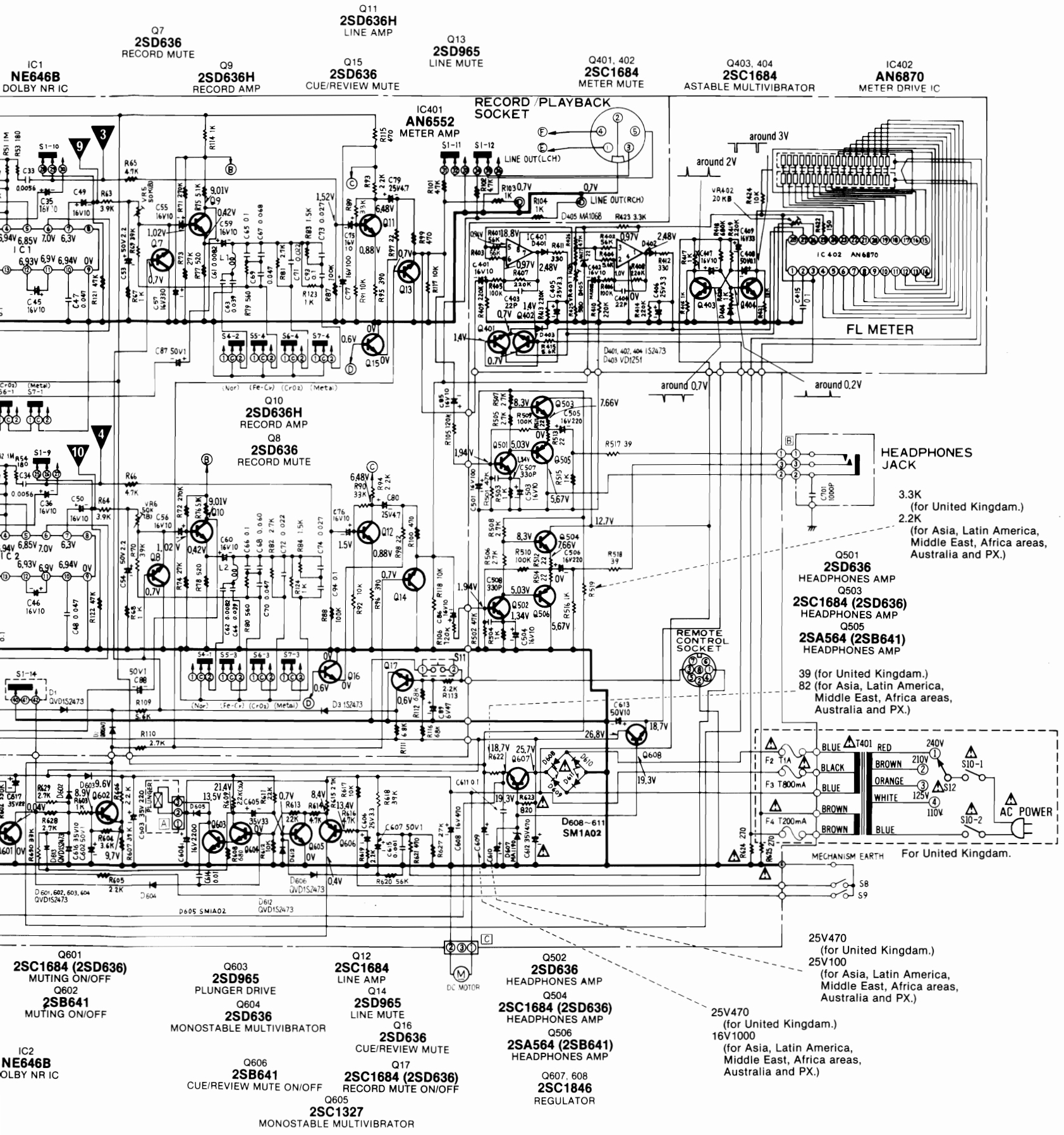

NOTE: RESISTORS

ERD	Carbon
ERG	Metal-oxide
ERO	Metal-film
ERX	Metal-film
ERQ	Fuse type metallic
ERC	Solid
ERF	Cement

CAPACITORS

ECG	Ceramic
ECK	Ceramic
ECC	Ceramic
ECF	Ceramic
ECQ	Polyester film
ECQE	Polyester film
ECQF	Polypropylene
ECE	Electrolytic
ECE	Non polar electrolytic
EQS	Polystyrene
ECS	Tantalum

EQUIVALENT CIRCUIT

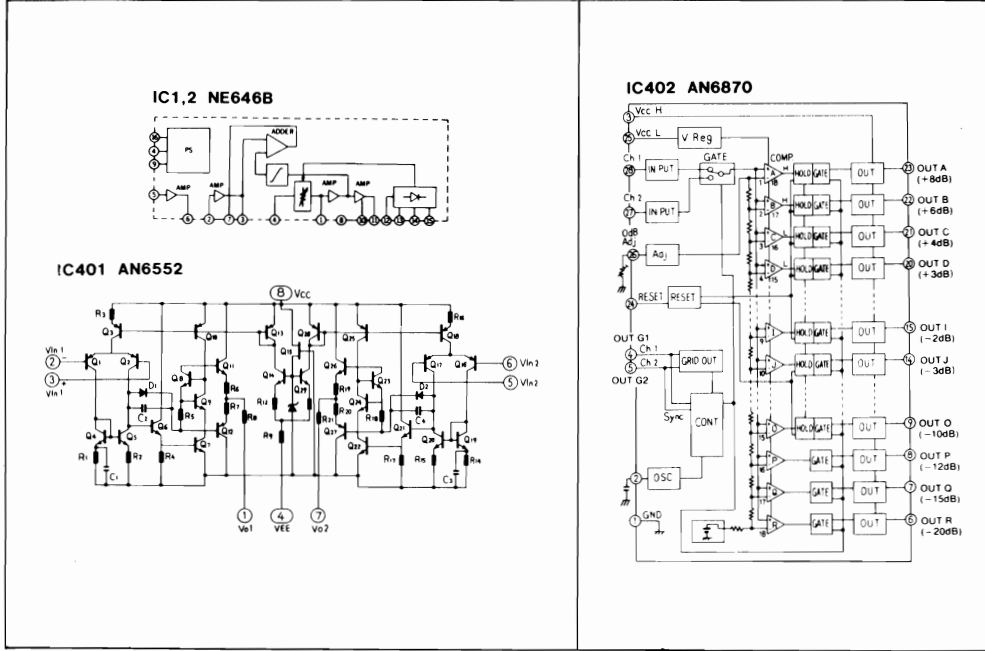

Ref. No.	Part No.	Ref. No.	Part No.
RESISTORS			
R1, 2	ERD25FJ100	R619	ERD25FJ222
R3, 4	ERD25J473	R619	ERD25FJ471
R5, 6	ERD25FJ101	R621	ERD25FJ471
R7, 8	ERD25J154	R622	ERQ12HJ390P
R9, 10	ERD25FJ471	*For United Kingdom.	
R11, 12	ERD25FJ101	*For Asia, Latin America, Middle East, Africa areas, Australia and PX.	
R13, 14	ERD25J224	*For Asia, Latin America, Middle East, Africa areas, Australia and PX.	
R17, 18	ERD25FJ822	R623	ERD50FJ821
R23, 24	ERD25FJ822	*For United Kingdom.	
R25, 26	ERD25J334	*For Asia, Latin America, Middle East, Africa areas, Australia and PX.	
R27, 28	ERD25FJ822	R27, 28	ERD25FJ822
R29, 30	ERD25FJ222	R29, 30	ERD25FJ222
R31, 32	ERD25FJ472	R31, 32	ERD25FJ472
R33, 34	ERD25FJ562	R33, 34	ERD25FJ562
R37, 38	ERD25J273	R37, 38	ERD25J273
R43	ERQ14AJ270	R43	ERQ14AJ270
*For United Kingdom.			
R43	ERD25FJ270	*For Asia, Latin America, Middle East, Africa areas, Australia and PX.	
R45, 46	ERD25J474	R45, 46	ERD25J474
R47, 48	ERD25J473	R47, 48	ERD25J473
R49, 50	ERD25FJ332	R49, 50	ERD25FJ332
R51, 52	ERD25J105	R51, 52	ERD25J105
R53, 54	ERD25FJ181	R53, 54	ERD25FJ181
R55, 56, 57, 58	ERD25FJ102	R55, 56, 57, 58	ERD25FJ102
R63, 64	ERD25FJ392	R63, 64	ERD25FJ392
R69, 70	ERD25J393	R69, 70	ERD25J393
R79, 80	ERD25FJ561	R79, 80	ERD25FJ561
R81, 82	ERD25FJ272	R81, 82	ERD25FJ272
R83, 84	ERD25FJ152	R83, 84	ERD25FJ152
R89, 90	ERD25J333	R89, 90	ERD25J333
R91, 92	ERD25FJ103	R91, 92	ERD25FJ103
R93, 94	ERD25FJ222	R93, 94	ERD25FJ222
R95, 96	ERD25FJ391	R95, 96	ERD25FJ391
R97, 98	ERD25FJ220	R97, 98	ERD25FJ220
R105, 106	ERD25J124	R105, 106	ERD25J124
R108	ERG1ANJ221	R108	ERG1ANJ221
R114	ERD25FJ102	R114	ERD25FJ102
R115	ERD25FJ471	R115	ERD25FJ471
R117, 118	ERD25FJ103	R117, 118	ERD25FJ103
R195, 196	ERD25FJ391	R195, 196	ERD25FJ391
R197, 98	ERD25FJ220	R197, 98	ERD25FJ220
R2105, 106	ERD25J124	R2105, 106	ERD25J124
R2108	ERG1ANJ221	R2108	ERG1ANJ221
R2114	ERD25FJ102	R2114	ERD25FJ102
R2115	ERD25FJ471	R2115	ERD25FJ471
R2117, 118	ERD25FJ103	R2117, 118	ERD25FJ103
R2511, 512, 513, 514	ERD25FJ220	R2511, 512, 513, 514	ERD25FJ220
R2516	ERD25FJ102	R2516	ERD25FJ102
R2517, 518	ERD25FJ390	R2517, 518	ERD25FJ390
R2519	ERD25FJ332	R2519	ERD25FJ332
*For United Kingdom.			
R2601	ERD25J333	R2601	ERD25J333
R2602	ERD25J334	R2602	ERD25J334
R2603	ERD25FJ102	R2603	ERD25FJ102
R2606	ERD25FJ222	R2606	ERD25FJ222
R2609	ERD50FJ222	R2609	ERD50FJ222
R2611	ERD25J223	R2611	ERD25J223
R2615	ERD25FJ272	R2615	ERD25FJ272
R2616	ERD25FJ472	R2616	ERD25FJ472
R2618	ERD25J393	R2618	ERD25J393
R2619	ERD25FJ222	R2619	ERD25FJ222
R2619	ERD25FJ471	R2619	ERD25FJ471
R2621	ERQ12HJ390P	R2621	ERQ12HJ390P
*For United Kingdom.			
R2622	ERQ12HJ390P	R2622	ERQ12HJ390P
*For Asia, Latin America, Middle East, Africa areas, Australia and PX.			
R2623	ERD50FJ821	R2623	ERD50FJ821
*For United Kingdom.			
R2624, 625	ERD50FJ271	R2624, 625	ERD50FJ271
*For United Kingdom.			
R2629	ERD25FJ272	R2629	ERD25FJ272
R2630	ERD25J333	R2630	ERD25J333
R2701, 702	ERD25FJ682	R2701, 702	ERD25FJ682
R123, 124	ERD25FJ102	R123, 124	ERD25FJ102
R301	ERD25FJ180	R301	ERD25FJ180
R302	ERD25FJ562	R302	ERD25FJ562
R304, 305	ERQ14AJ150	R304, 305	ERQ14AJ150
*For United Kingdom.			
R306	ERD25FJ122	R306	ERD25FJ122
R307, 308	ERD25FJ220	R307, 308	ERD25FJ220
R309	ERD25J223	R309	ERD25J223
R310	ERD25J183	R310	ERD25J183
R311	ERD25J683	R311	ERD25J683
R312	ERD25J123	R312	ERD25J123
R313	ERQ12HJ150	R313	ERQ12HJ150
*For United Kingdom.			
R401, 402, 403, 404	ERD25FJ563	R401, 402, 403, 404	ERD25FJ563
R405, 406	ERD25J104	R405, 406	ERD25J104
R407, 408, 409, 410	ERD25J224	R407, 408, 409, 410	ERD25J224
R411, 412	ERD25J331	R411, 412	ERD25J331
R413, 414	ERD25J224	R413, 414	ERD25J224
R415	ERD25FJ562	R415	ERD25FJ562
R416, 417	ERD25FJ102	R416, 417	ERD25FJ102
R418	ERD25FJ684	R418	ERD25FJ684
R419	ERD25J124	R419	ERD25J124
R420	ERD25J220	R420	ERD25J220
R421	ERD25J153	R421	ERD25J153
R422	ERQ14AJ151	R422	ERQ14AJ151
*For United Kingdom.			
R423	ERD25FJ151	R423	ERD25FJ151
*For Asia, Latin America, Middle East, Africa areas, Australia and PX.			
R424	ERD25FJ103	R424	ERD25FJ103
R425	ERD25FJ561	R425	ERD25FJ561
R426	ERD25FJ472	R426	ERD25FJ472
R427	ERD25FJ220	R427	ERD25FJ220

SPECIFICATIONS * Input level control ... MAX

Playback S/N ratio Test tape ... QZZCFM	More than 45 dB (without NAB filter)
Overall distortion Test tape ... QZZCRA for Normal ... QZZCRX for CrO ₂ ... QZZCRY for Fe-Cr ... QZZCRZ for Metal	Less than 4%
Overall S/N ratio Test tape ... QZZCRA	More than 43 dB (without NAB filter)

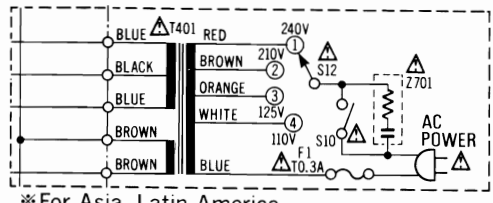

*For Asia, Latin America, Middle East, Africa areas and PX.

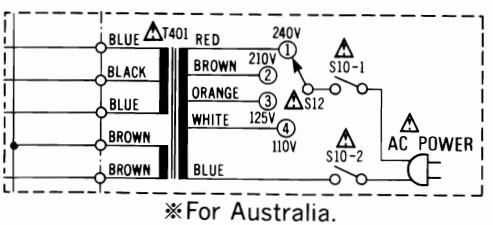

*For Australia.

NOTE:

- S1-1 - S1-4 Record/playback select switch (shown in playback position).
- S2-1 - S2-4 Input select switch (shown in LINE position).
- S3-1 - S3-4 Dolby NR IN/OUT select switch (shown in OUT position).
- S4-1, S4-2 Tape select switch (for Normal tape, shown in ON position).
- S5-1 - S5-4 Tape select switch (for Fe-Cr tape, shown in OFF position).
- S6-1 - S6-4 Tape select switch (for CrO₂ tape, shown in OFF position).
- S7-1 - S7-4 Tape select switch (for Metal tape, shown in OFF position).
- S8 Cue and review muting switch (Close at cue/review mode).
- S9 Playback muting switch (Close at playback or record mode).
- S10-1, S10-2 Power ON/OFF switch.
- S11 Record muting switch (shown in OFF position).
- S12 AC power voltage select switch.
- VR1, 2 Input level control.
- VR3, 4 Playback gain adjustment VR.
- VR5, 6 Record gain adjustment VR.
- VR301 Erase current adjustment VR (for Metal tape position).
- VR302 Bias current adjustment VR (for Normal tape position, L-CH).
- VR303 Bias current adjustment VR (for Metal tape position, L-CH).
- VR304 Bias current adjustment VR (for Metal tape position, R-CH).
- VR401 FL meter adjustment VR (for -20dB indication).
- VR402 FL meter adjustment VR (for 0dB indication).
- L3, 4 Bias leakage adjustment coil.
- Resistances are in ohms (Ω), 1/4 watt unless specified otherwise. K = 1,000Ω.
- Resistors indicated thickly show printed type resistor.
- Capacity are in microfarads (μF) unless specified otherwise. P = Pico-farads.
- The mark (▼) shows test point. e.g. ▼ = Test point 1.
- All voltage values shown in circuitry are under no signal condition and record mode with volume control at minimum position.
- For measurement, use VTM.
- Δ indicates that only parts specified by the manufacturer used for safety.
- Parts No. in () show for Asia, Latin America, Middle East, Africa areas, Australia and PX.

CIRCUIT BOARD

NOTE: Δ indicates that only parts specified by the manufacturer be used for safety.

MAIN CIRCUIT BOARD

Ref. No.	Part No.	Ref. No.	Part No.
R501, 502	ERD25TJ473		
R506, 508	ERD25FJ272		
R509	ERD25TJ104		
VARIABLE RESISTORS			
VR1, 2	EWKN3AF21A24		
VR3, 4	EVNK4AA0B24		
VR5, 6	EVNK4AA0B54		
VR301, 302	EVNK4AA0B54		
VR303, 304	EVNK4AA0B15		
VR401	EVNK4AA0B13		
VR402	EVNK4AA0B24		
CAPACITORS			
C3, 4	ECEA16M10		
C5, 6	ECKD1H471KB		
C7, 8	ECKD1H102MD		
C9, 10	ECEA1ES101		
COMBINATION PART			
C11, 12, 13, 14	ECEA1AS470		
C15, 16	ECEA1JS47		
C17, 18	ECQM1H153JZ		
C19, 20	ECDD1H121KD		
C21, 22	ECFDD123KVY		
C23, 24	ECKD1H103ZF		
C25, 26	ECEA50MR33		
C27, 28	ECEA1HS100		
C29, 30	ECQM1H472JZ		
C31	ECQM1H273JZ		
C32	ECQM1H273JZ		
C33, 34	ECQM1H562JZ		
C35, 36	ECEA1HS100		
C37, 38	ECEA1AS470		
C39	ECEA1ES470		
C41, 42	ECEA50ZR33		
C43, 44	ECFDD104MXY		
C45, 46	ECEA1HS100		
C47, 48	ECFDD473KXY		
C49, 50	ECEA1HS100		
C53, 54	ECEA2AS2R2		
C55, 56	ECEA1HS100		
C57	ECEA1CS331		
C59, 60	ECEA1HS100		
C61, 62	ECFDD822KVY		
C63, 64	ECQM1H393JZ		
C65, 66	ECFDD104KXY		
C67, 68	ECFDD683KXY		
C69, 70	EVFDD473KXY		
C71, 72	ECFDD223KXY		
C73, 74	ECFDD273KXY		
C75, 76	ECEA1HS100		
C77	ECEA1ES101		
C79, 80	ECEA1JS47		
C81, 82	ECQP1122JZ		
C83, 84	ECFDD562KVY		
C85, 86	ECEA1HS100		
C87, 88	ECEA2AS010		
C89	ECEA1AS470		
C91, 92	ECKD1H102MD		
C93, 94	ECFDD104KXY		
C301, 302	ECDD1H121KD		
C303	ECQP1183JZ		
C304	ECEA2AS010		
C305, 306	ECFDD223MXY		
C307	ECEA1HS100		
C401, 402	ECEA1HS100		
C403, 404	ECDD1H220KD		
C405, 406	ECEA2AS3R3		
C407	ECEA1HS100		
C408	ECEA50ZR1		
C409	ECEA1CS330		
C415	ECFDD473MXY		
C501	ECEA1ES101		
C503, 504	ECEA1HS100		
C505, 506	ECEA1CS221		
C507	ECDD1H331KD		
C508	ECDD1H331KD		
C601	ECEA1HS470		
C602	ECEA2AS010		
C603	ECEA1VS221		
C604	ECEA1VS330		
C605	ECEA2AS3R3		
C606	ECEA2AS010		
C607	ECEA1CS471		
C608	ECEA1CS471		
C609	ECEA1ES471		
DIODES & RECTIFIERS			
D1, 2, 3	MA161		
D401, 402	MA161		
D403	RVDB265E		
D404	MA161		
D405	RVDRD68EB		
D601, 602, 603, 604	MA161		
D605	SM112		
D606	MA161		
D607	MA1190LF		
D608, 609, 610, 611	SM112		
D612, 613	MA161		
INTEGRATED CIRCUITS			
IC1, 2	NE646B		
IC401	AN6552		
IC402	AN6870		

IC1.2 NE646B

1	6.9V	9	0V
2	7.0V	10	7.0V
3	7.5V	11	6.9V
4	6.9V	12	6.9V
5	6.9V	13	—
6	7.1V	14	6.9V
7	6.3V	15	6.8V
8	—	16	13.5V

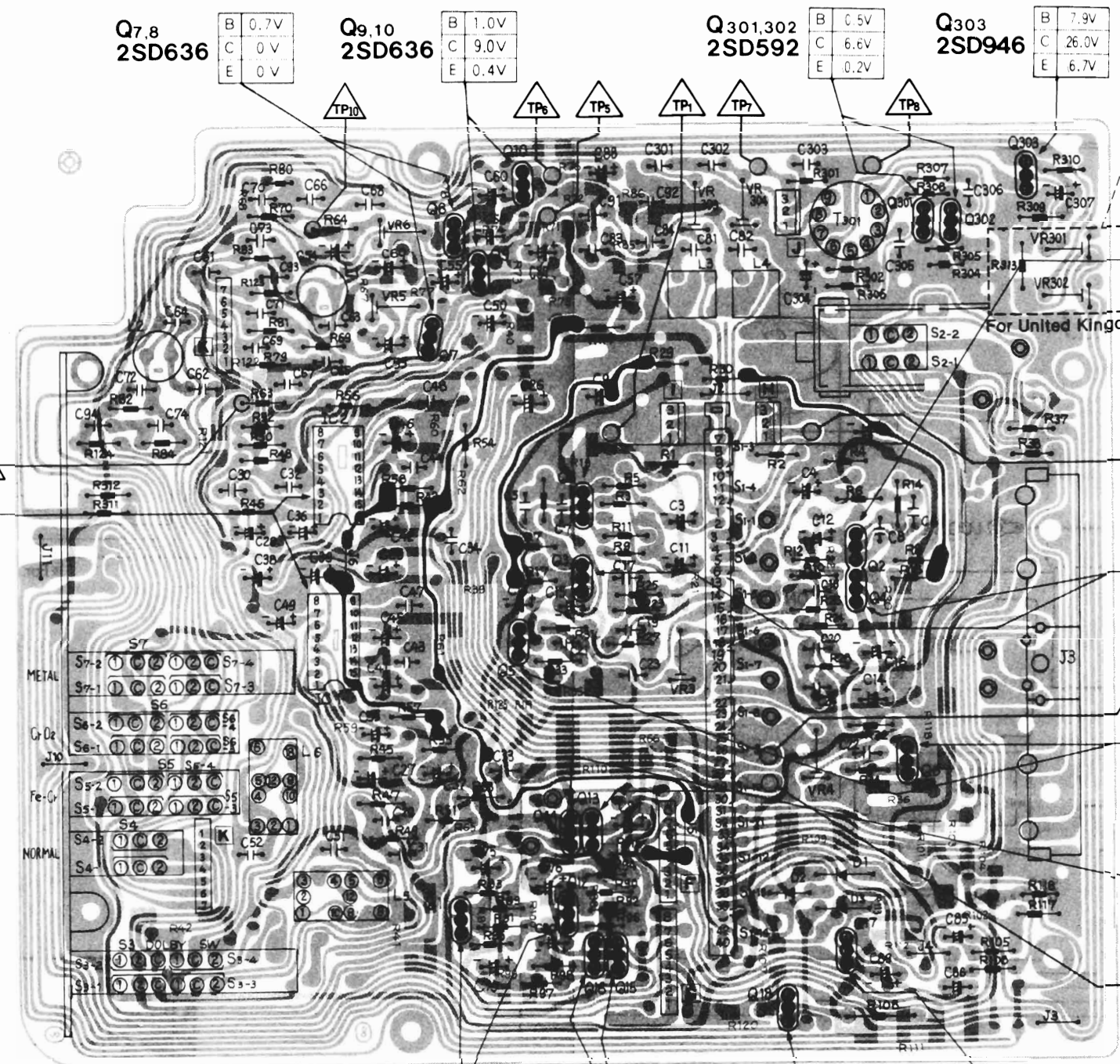

For Asia, Latin America, Middle East, Africa erase, Australia and PX.

POWER SUPPLY CIRCUIT BOARD

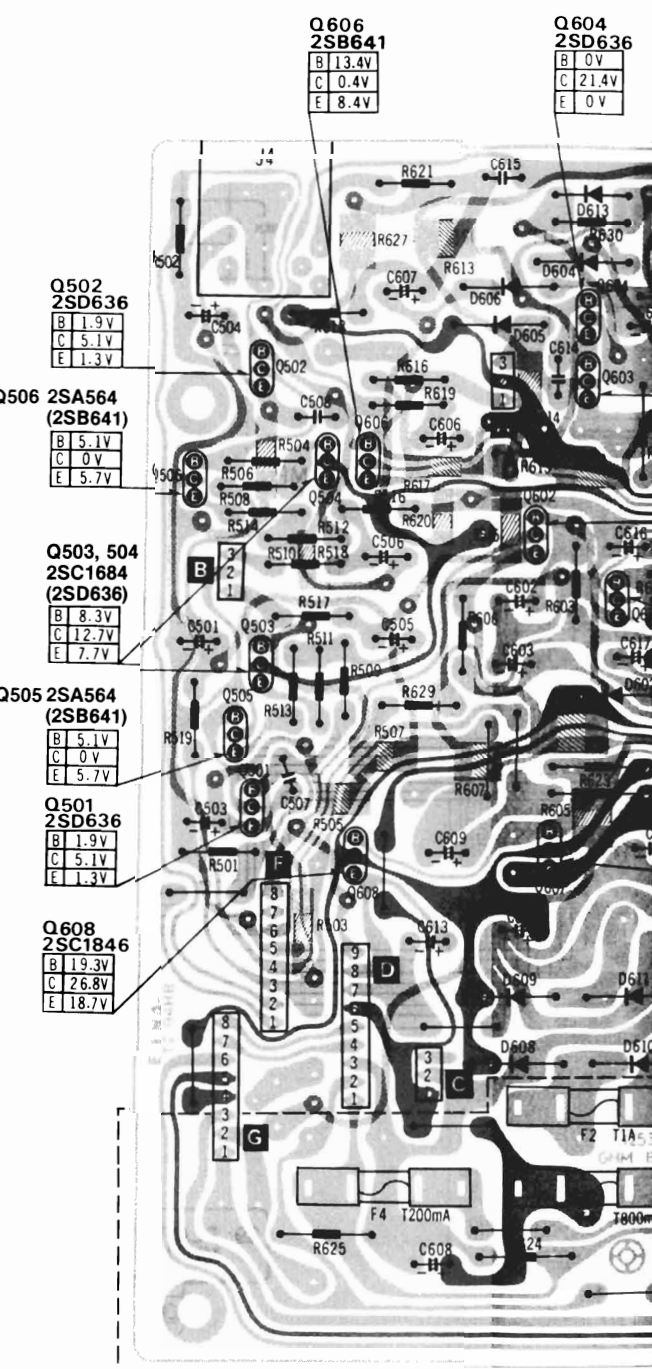

Ref. No.	Part No.	Part Name & Description	Ref. No.	Part No.	Part Name & Description	Ref. No.	Part No.	Part Name & Description	Ref. No.	Part No.	Part Name & Description
T301	QLB0193K	Oscillation Transformer	L5, 6	QLM927	MPX Filter	S10	QSW2214A	Push Switch (Power ON/OFF)	F3	XBAQ0009	Fuse (T 800mA)
T401	QLPD43ELX	Power Transformer	S1	QSSE203T	Slide Switch (Record/Playback Selector)	S11	QSW1115AZ	"	F4	XBAQ0013	Fuse (T 200mA)
	QLPA54ELX	"	S2	QSW2233A	Push Switch (LINE IN/MIC Selector)	S12	QSR1407H	Rotary Switch (AC Voltage Selector)	JACKS		
	QLPA54ELX	"	S3, 4, 5, 6, 7	QSWX503A	Push Switch (Dolby ON/OFF and Tape Selector)	F1	XBA2E03NS5	Fuse (0.3A)	J1	QJA0257H	Microphone Jack
L1, 2	QLQX0332K	Peaking Coil	S8	QSB0251I	Leaf Switch (Playback Muting Switch)	F2	XBAQ0004	Fuse (T 1A)	J2	QJA0249C	Headphones Jack
L3, 4	QLQC0331	Bias Trap Coil	S9	QSB0251I	Leaf Switch (Cue/Review Muting Switch)				J3	QEJ5002S	Jack Board
									J4	QJS1956H	Remote Control Socket

CIRCUIT BOARD

NOTE: Δ indicates that only parts specified by the manufacturer be used for safety.

MAIN CIRCUIT BOARD

For Asia, Latin America, Middle East, Africa erase, Australia and PX.

Ref. No.	Part No.	Ref. No.	Part No.
R501, 502	ERD25TJ473		
R506, 508	ERD25FJ272		
R509	ERD25TJ104		
VARIABLE RESISTORS			
VR1, 2	EWKN3AF21A24		
VR3, 4	EVNK4AA00B24		
VR5, 6	EVNK4AA00B54		
VR301, 302	EVNK4AA00B54		
VR303, 304	EVNK4AA00B15		
VR401	EVNK4AA00B13		
VR402	EVNK4AA00B24		
CAPACITORS			
C3, 4	ECEA16M10		
C5, 6	ECKD1H471KB		
C7, 8	ECKD1H102MD		
C9, 10	ECEA1ES101		
COMBINATION PART			
C11, 12, 13, 14	ECEA1ES470		
C15, 16	ECEA1S470		
C17, 18	EQM1H153JZ		
C19, 20	ECCD1H121KD		
C21, 22	ECFDD123KXY		
C23, 24	ECKD1H103ZF		
C25, 26	ECEA50MR33		
C27, 28	ECEA1HS100		
C29, 30	EQM1H472JZ		
C31	EQM1H273JZ		
C32	EQM1H273JZ		
C33, 34	EQM1H562JZ		
C35, 36	ECEA1HS100		
C37, 38	ECEA1S470		
C39	ECEA1ES470		
C41, 42	ECEA50ZR33		
C43, 44	ECFDD104MXY		
C45, 46	ECEA1HS100		
C47, 48	ECFDD473KXY		
C49, 50	ECEA1HS100		
C53, 54	ECEA2AS2R2		
C55, 56	ECEA1HS100		
C57	ECEA1CS331		
C59, 60	ECEA1HS100		
C61, 62	ECFDD22KXY		
C63, 64	EQM1H393JZ		
C65, 66	ECFDD104KXY		
C67, 68	ECFDD683KXY		
C69, 70	EVFDD473KXY		
C71, 72	ECFDD223KXY		
C73, 74	ECFDD273KXY		
C75, 76	ECEA1HS100		
C77	ECEA1ES101		
C79, 80	ECEA1S470		
C81, 82	EQP1122JZ		
C83, 84	ECFDD562KXY		
C85, 86	ECEA1HS100		
C87, 88	ECEA2AS010		
C89	ECEA1S470		
C91, 92	ECKD1H102MD		
C93, 94	ECFDD104KXY		
C301, 302	ECCD1H121KD		
C303	EQP1183JZ		
C304	ECEA2AS010		
C305, 306	ECFDD223MXY		
C307	ECEA1HS100		
C401, 402	ECEA1HS100		
C403, 404	ECCD1H220KD		
C405, 406	ECEA2AS3R3		
C407	ECEA1HS100		
C408	ECEA50ZR1		
C409	ECEA1CS330		
C415	ECFDD473MXY		
C501	ECEA1ES101		
C503, 504	ECEA1HS100		
C505, 506	ECEA1CS221		
C507	ECCD1H331KD		
C508	ECCD1H331KD		
C601	ECEA1HS470		
C602	ECEA2AS010		
C603	ECEA1VS221		
C604	ECEA1CS222		
C605	ECEA1VS330		
C606	ECEA2AS3R3		
C607	ECEA2AS010		
C608	ECEA1CS471		
C609	ECEA1ES471		
DIODES & RECTIFIERS			
D1, 2, 3	MA161		
D401, 402	MA161		
D403	RVDK8265E		
D404	MA161		
D405	RVDRD6R8EB		
D601, 602, 603, 604	MA161		
D605	SM112		
D606	MA161		
D607	MA119OLF		
D608, 609, 610, 611	SM112		
D612, 613	MA161		
INTEGRATED CIRCUITS			
IC1, 2	NE646B		
IC401	AN6552		
IC402	AN6870		

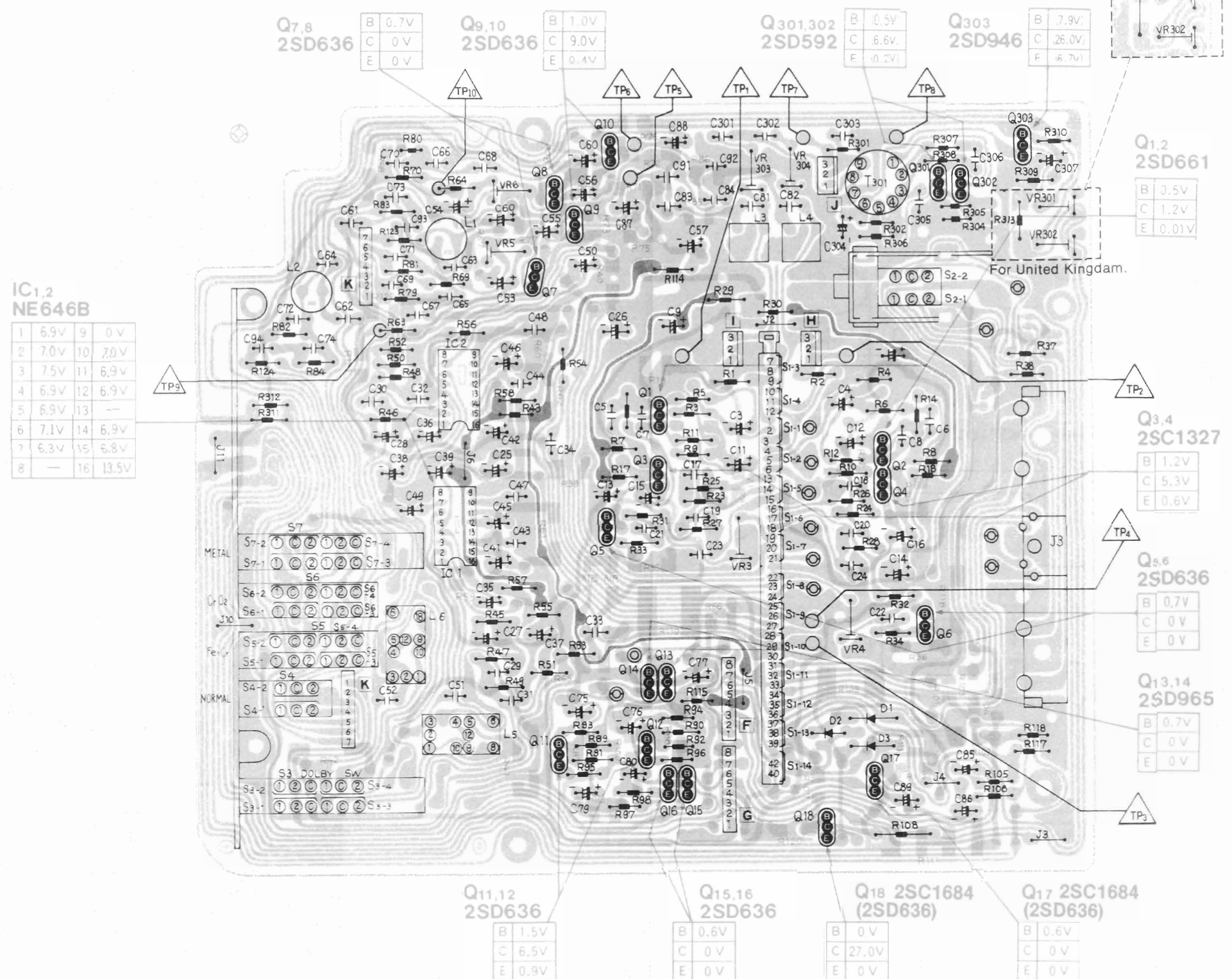

Ref. No.	Part No.	Part Name & Description	Ref. No.	Part No.	Part Name & Description	Ref. No.	Part No.	Part Name & Description	Ref. No.	Part No.	Part Name & Description
T301	QLB0193K	Oscillation Transformer	L5, 6	QLM927	MPX Filter	S10	QSW2214A	Push Switch (Power ON/OFF)	F3	XBAQ0009	Fuse (T 800mA)
T401	QLPD43ELX	Power Transformer	S1	QSS203T	Slide Switch (Record/Playback Selector)	S11	QSW2103A	Push Switch (Rec. Mute ON/OFF)	F4	XBAQ0013	Fuse (T 200mA)
TRANSFORMERS											
SWITCHES											
S2	QSW2233A	Push Switch (LINE IN/MIC Selector)	S3, 4, 5, 6, 7	QSWX503A	Push Switch (Dolby ON/OFF and Tape Selector)	S12	QSR1407H	Rotary Switch (AC Voltage Selector)	JACKS		
COILS											
L1, 2	QLQX0332K	Peaking Coil	S8	QSB0251I	Leaf Switch (Playback Muting Switch)	F1	XBA2E03N5	Fuse (0.3A)	J1	QJA0257H	Microphone Jack
L3, 4	QLQC0331	Bias Trap Coil	S9	QSB0251I	Leaf Switch (Cue/Review Muting Switch)	F2	XBAQ0004	Fuse (T 1A)	J2	QJA0249C	Headphones Jack
FUSES											
TRANSISTORS											
Q1, 2	2SD661T		Q3	2SC1327		Q4	2SD661T		J3	QJ5002S	Jack Board
Q3	2SC1327		Q4	2SD661T		Q5	2SD636R		J4	QJS1956H	Remote Control Socket
Q5, 6, 7, 8	2SD636R		Q9, 10, 11	2SD636HR		Q12	2SC1684		TRANSISTORS		
Q9, 10, 11	2SD636HR		Q12	2SC1684		Q13, 14	2SD965		TRANSISTORS		
Q12	2SC1684		Q13, 14	2SD965		Q15, 16	2SD636		TRANSISTORS		
Q13, 14	2SD965		Q15, 16	2SD636R		Q17, 18	2SC1684		TRANSISTORS		
Q15, 16	2SD636R		Q17, 18	2SC1684		Q18	2SC1684 (2SD636)		TRANSISTORS		
Q17, 18	2SC1684		Q301, 302	2SD592NC5		Q303	2SD946		TRANSISTORS		
Q301, 302	2SD592NC5		Q401, 402, 403, 404	2SC1684		Q501	2SD636		TRANSISTORS		
Q401, 402, 403, 404	2SC1684		Q501, 502	2SD636R		Q503, 504	2SC1684		TRANSISTORS		
Q501, 502	2SD636R		Q503, 504	2SC1684		Q505, 506	2SC1684		TRANSISTORS		
Q503, 504	2SC1684		Q505, 506	2SC1684		Q601	2SC1684		TRANSISTORS		
Q505, 506	2SC1684		Q601	2SC1684		Q602	2SB641R		TRANSISTORS		
Q601	2SC1684		Q602	2SB641R		Q603	2SD965		TRANSISTORS		
Q602	2SB641R		Q603	2SD965		Q604	2SD636R		TRANSISTORS		
Q603	2SD965		Q604	2SD636R		Q605	2SD661T		TRANSISTORS		
Q604	2SD636R		Q605	2SD661T		Q606	2SB641R		TRANSISTORS		
Q605	2SD661T		Q606	2SB641R		Q607, 608	2SC1684		TRANSISTORS		
Q606	2SB641R		Q607, 608	2SC1684		TRANSISTORS					
Q607, 608	2SC1684		TRANSISTORS								

POWER SUPPLY CIRCUIT BOARD

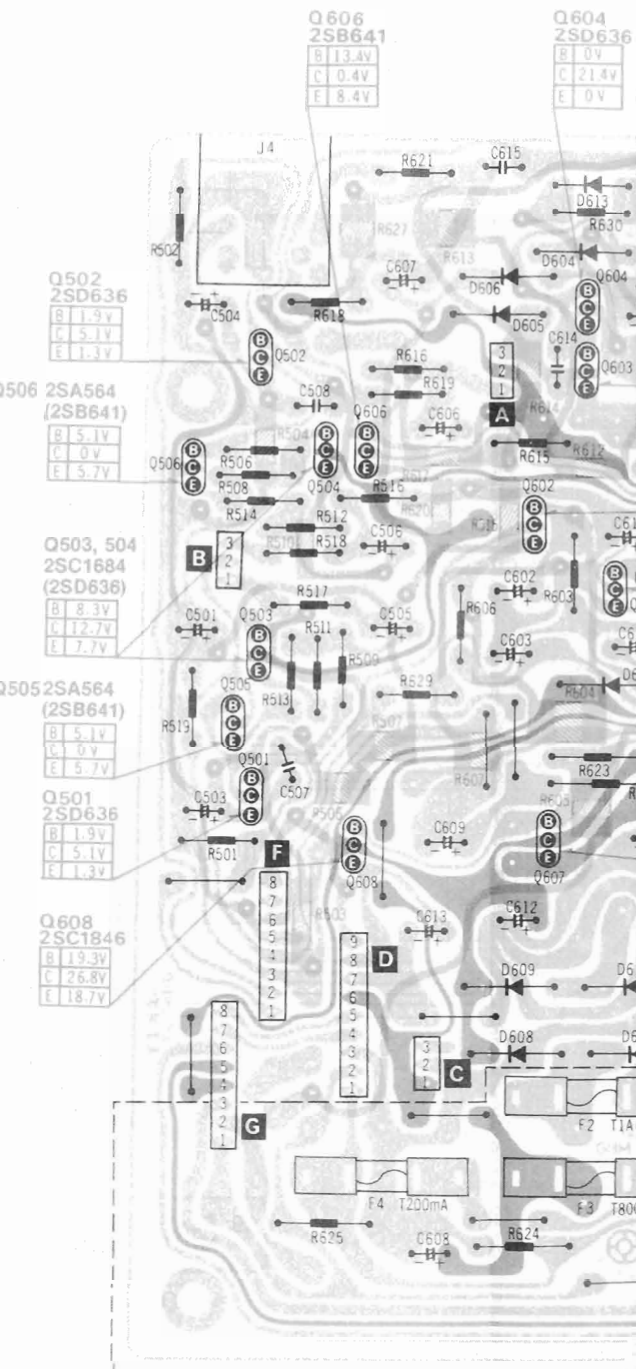

For Asia, Latin America, Middle East, Africa areas, Australia and PX.

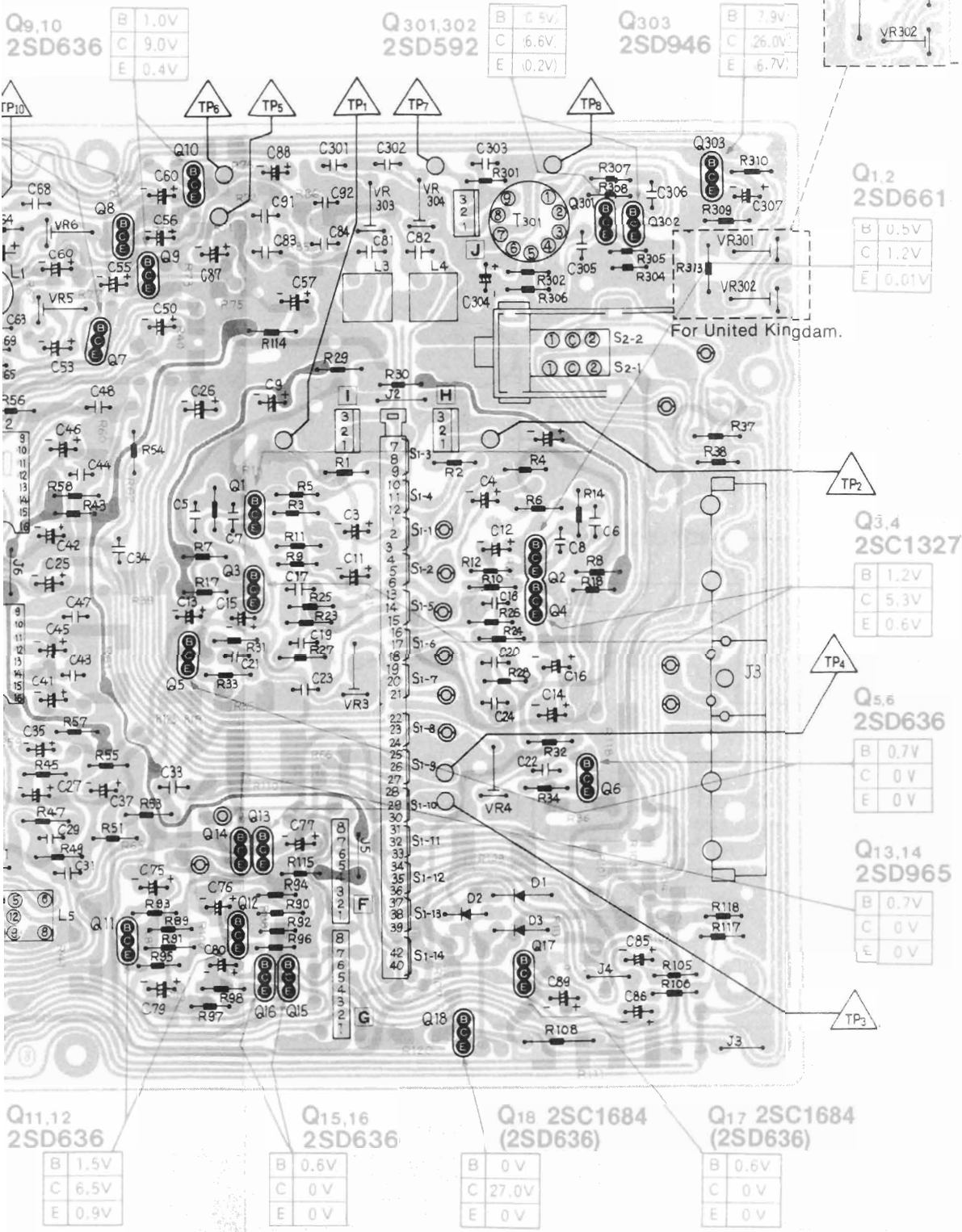

POWER SUPPLY CIRCUIT BOARD

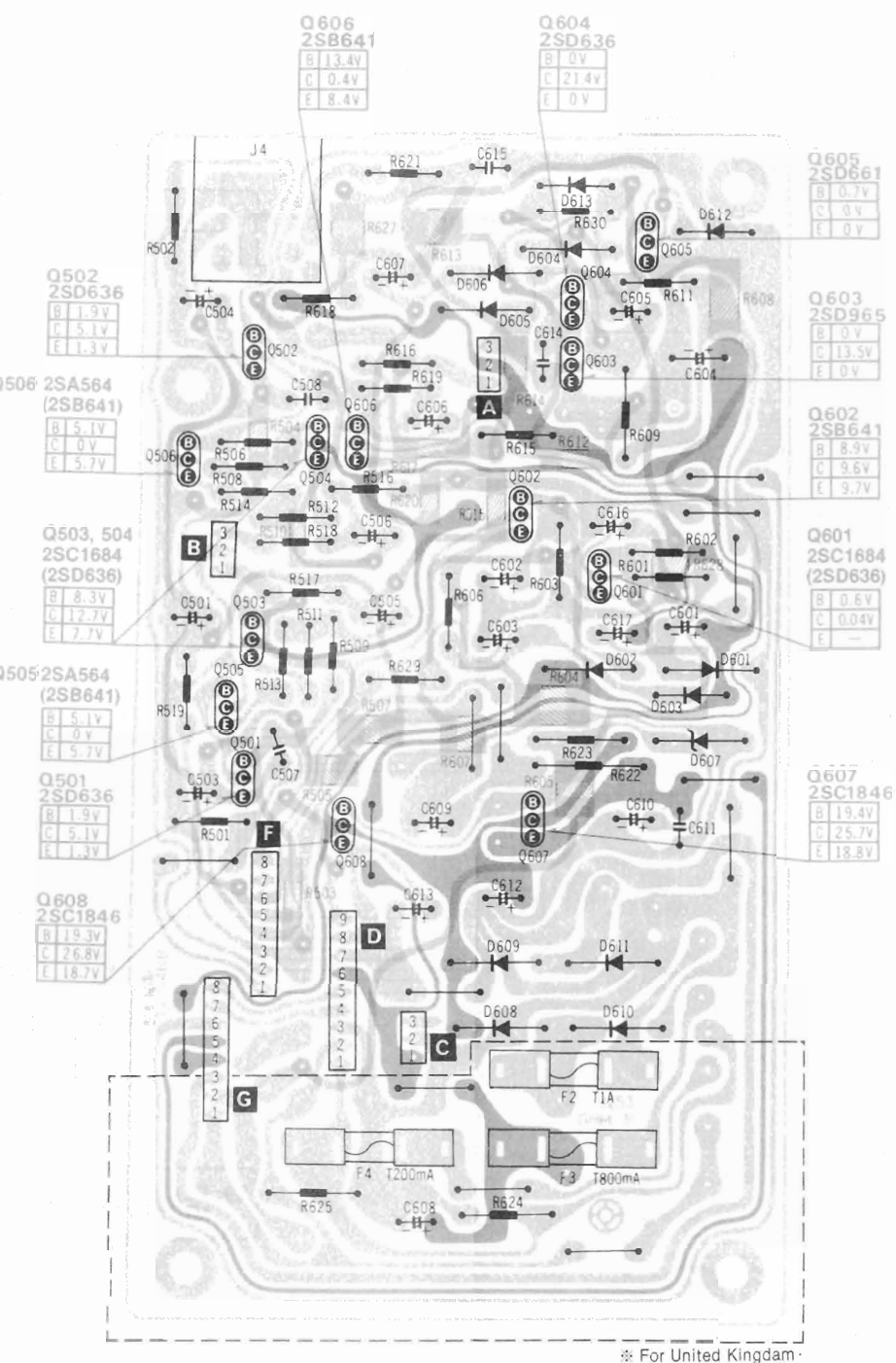

FL METER CIRCUIT BOARD

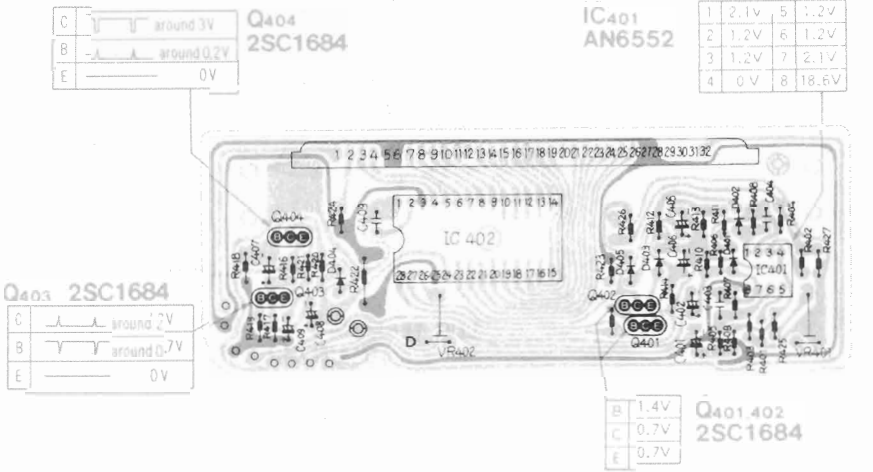

* For Asia, Latin America, Middle East, Africa areas and PX.

NOTE:

- The circuit shown in [shaded area] on the conductor is +B (bias) circuit.
- The circuit shown in [unshaded area] on the conductor indicates printed circuit, which is included printed type resistors.
- The circuit shown in [dotted area] on the conductor indicates printed circuit on the back side of the printed circuit board.
- Values indicated in [rectangle] are DC voltage between the ground and electrical parts.
- Parts No. in () show for Asia, Latin America, Middle East, Africa areas, Australia and PX.

description	Ref. No.	Part No.	Part Name & Description	Ref. No.	Part No.	Part Name & Description
	S10	QSW2214A	Push Switch (Power ON/OFF)	F3	XBAQ0009	Fuse (T 800mA)
		QSW1115AZ	"	F4	XBAQ0013	Fuse (T 200mA)
Selector	S11	QSW2103A	Push Switch (Rec Mute ON/OFF)	JACKS		
I/MIC Selector	S12	QSR1407H	Rotary Switch (AC Voltage Selector)			
Headphone Selector	F1	XBA2E03NSE	Fuse (0.3A)	J1	QJA0257H	Microphone Jack
Line Selector	F2	XBAQ 0004	Fuse (T 1A)	J2	QJA0249C	Headphones Jack
Switch				J3	QEJ5002S	Jack Board
				J4	QJS1956H	Remote Control Socket

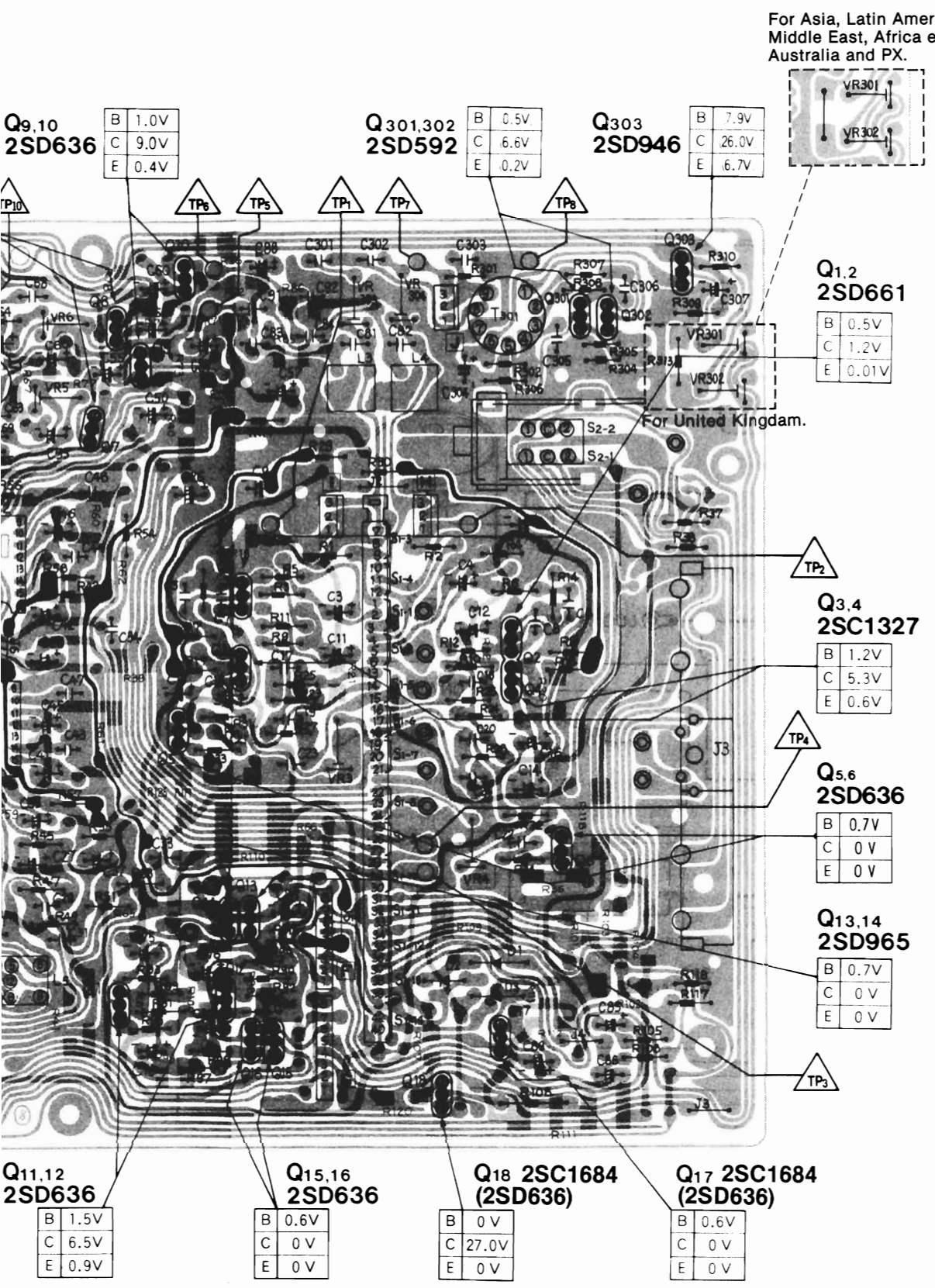

POWER SUPPLY CIRCUIT BOARD

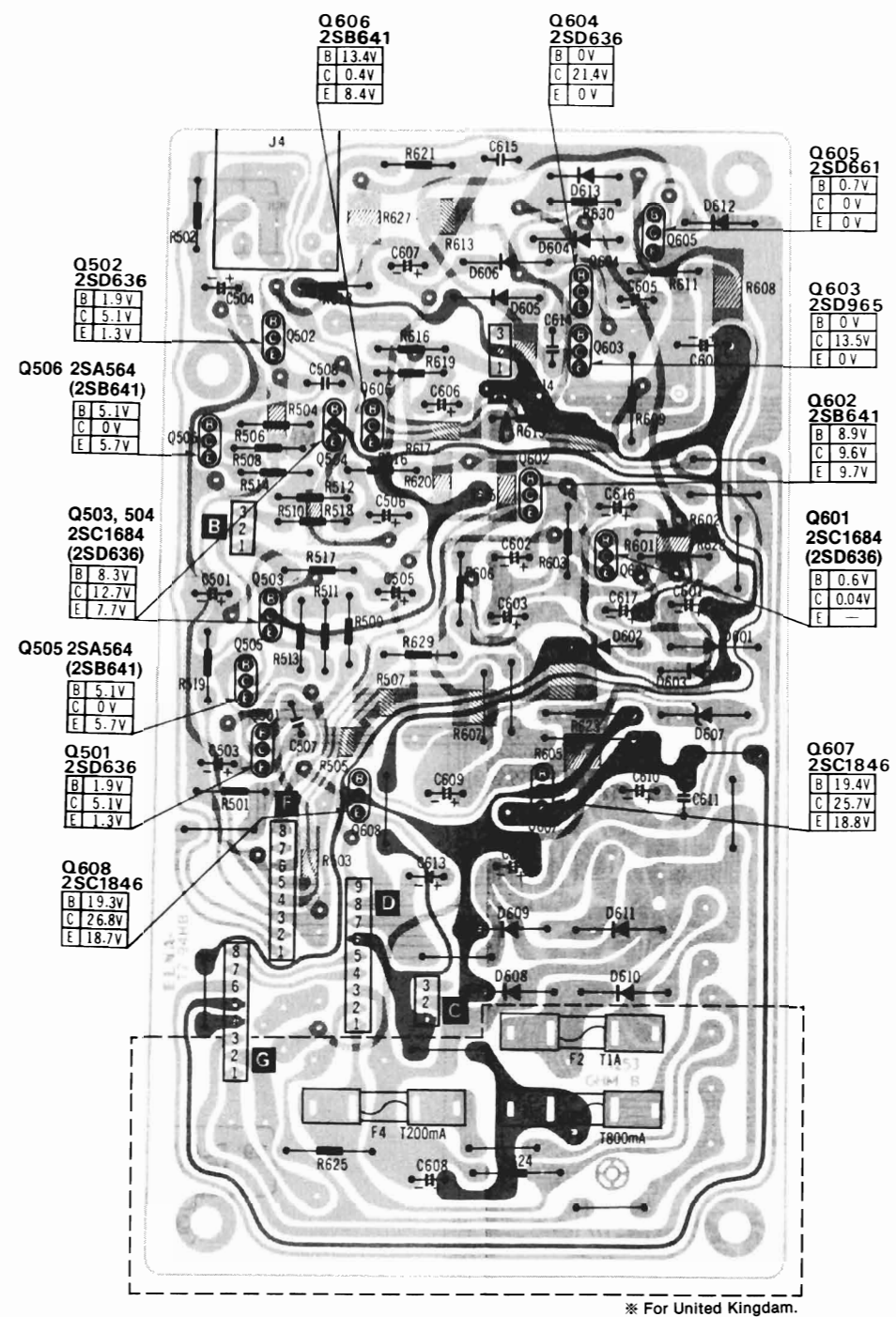

FL METER CIRCUIT BOARD

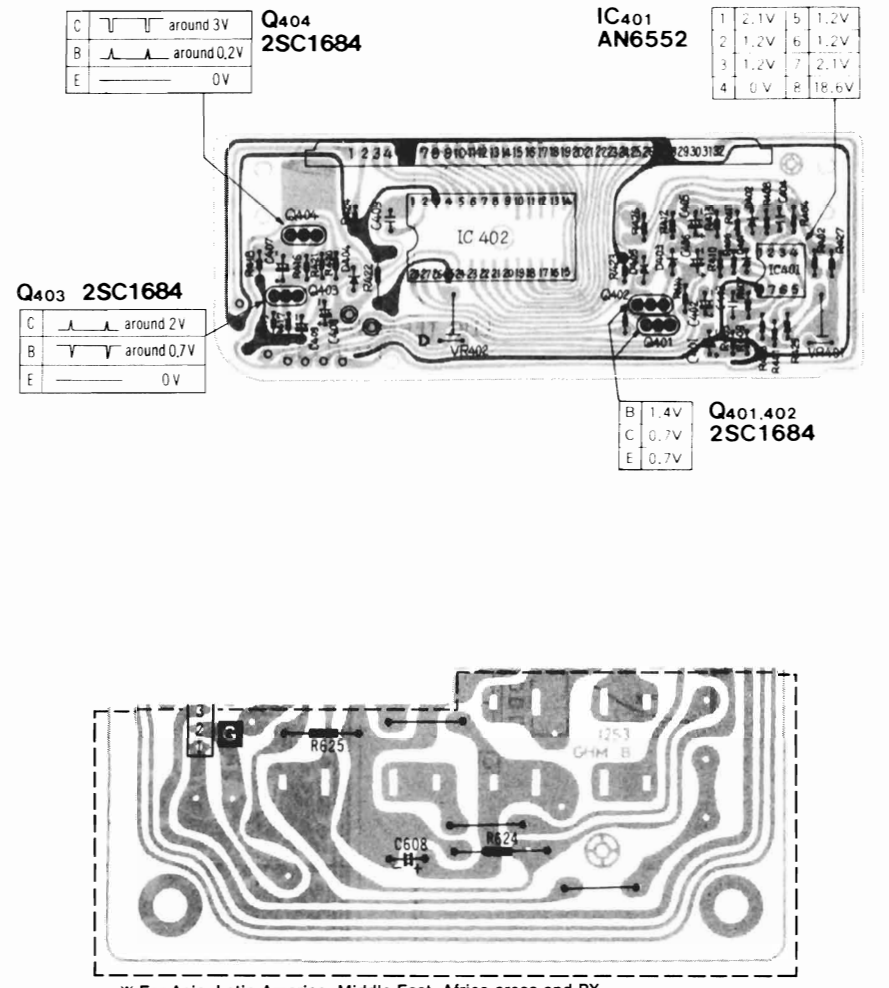

description	Ref. No.	Part No.	Part Name & Description	Ref. No.	Part No.	Part Name & Description
Push Switch (Power ON/OFF)	S10	QSW2214A	Push Switch (Power ON/OFF)	F3	XBAQ0009	Fuse (T 800mA)
*For United Kingdom and Australia.				*For United Kingdom.		
Push Switch (Rec Mute ON/OFF)	S11	QSW2103A	Push Switch (Rec Mute ON/OFF)	F4	XBAQ0013	Fuse (T 200mA)
/MIC Selector)	S12	QSR1407H	Rotary Switch (AC Voltage Selector)	*For United Kingdom.		
Rotary Switch (AC Voltage Selector)						
JACKS						
Microphone Jack	J1	QJA0257H	Microphone Jack	J2	QJA0249C	Headphones Jack
Headphones Jack	J2	QJA0249C	Headphones Jack	J3	QEJ5002S	Jack Board
Jack Board	J3	QEJ5002S	Jack Board	J4	QJS1956H	Remote Control Socket
Remote Control Socket	J4	QJS1956H	Remote Control Socket			
FUSES						
Fuse (0.3A)	F1	XBA2E03NS5	Fuse (0.3A)			
*For Asia, Latin America, Middle East, Africa areas and PX.						
Fuse (T 1A)	F2	XBAQ0004	Fuse (T 1A)			
*For United Kingdom.						

WIRING CONNECTION DIAGRAM

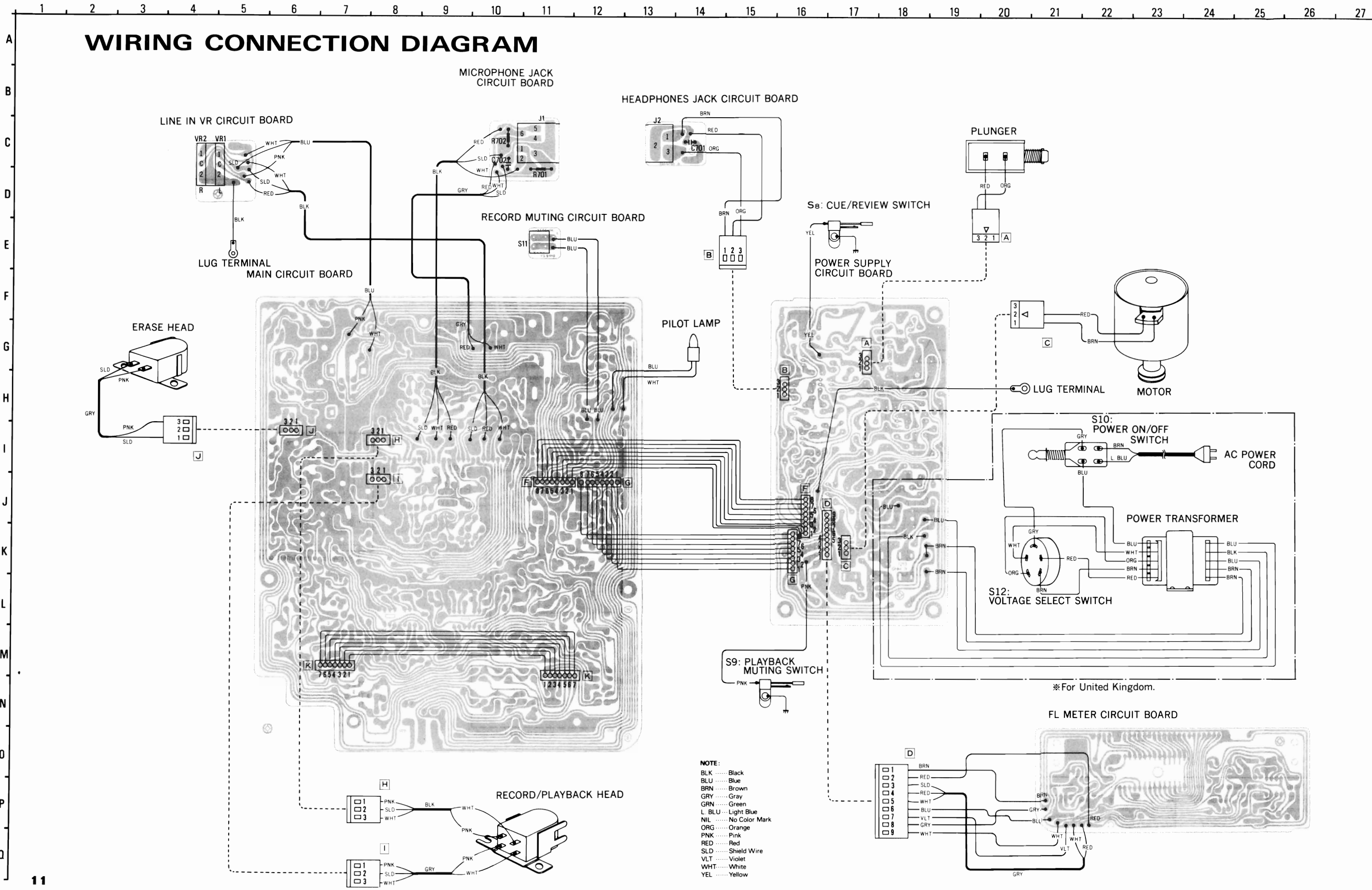

NOTE:
 BLK Black
 BLU Blue
 BRN Brown
 GRY Gray
 GRN Green
 L. BLU Light Blue
 NIL No Color Mark
 ORG Orange
 PNK Pink
 RED Red
 SLD Shield Wire
 VLT Violet
 WHT White
 YEL Yellow

※For United Kingdom.

CK
RD

HEADPHONES JACK CIRCUIT BOARD

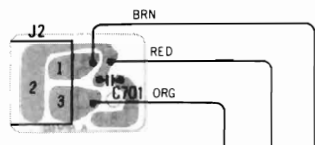

ATING CIRCUIT BOARD

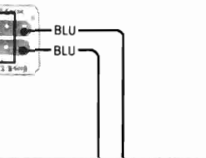

Sa: CUE/REVIEW SWITCH



POWER SUPPLY CIRCUIT BOARD

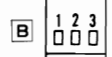

PLUNGER

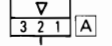
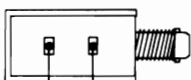

LUG TERMINAL

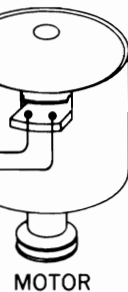

S10: POWER ON/OFF SWITCH

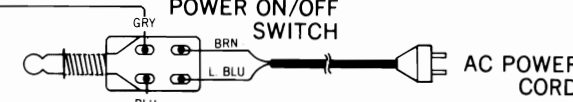

POWER TRANSFORMER

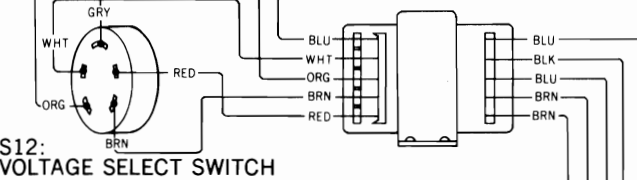

S12: VOLTAGE SELECT SWITCH

※For United Kingdom.

FL METER CIRCUIT BOARD

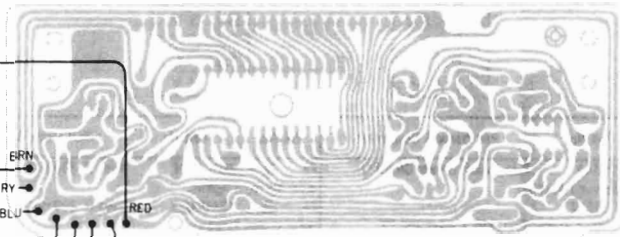

NOTE:

- BLKBlack
- BLUBlue
- BRNBrown
- GRYGray
- GRNGreen
- L. BLU...Light Blue
- NILNo Color Mark
- ORGOrange
- PNKPink
- REDRed
- SLDShield Wire
- VLTViolet
- WHTWhite
- YELYellow

PLAYBACK HEAD

SPARK KILLER

FUSE HOLDER

S10: POWER ON/OFF SWITCH

AC POWER CORD

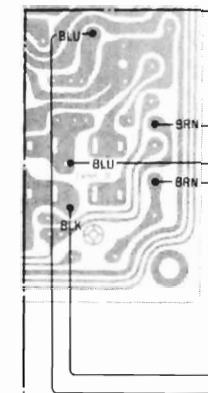

POWER TRANSFORMER

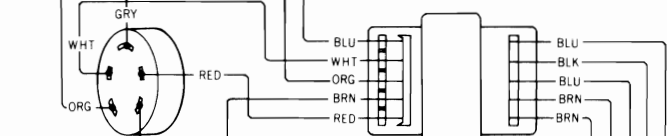

S12: VOLTAGE SELECT SWITCH

※For Asia, Latin America, Middle East, Africa areas and PX.

S10: POWER ON/OFF SWITCH

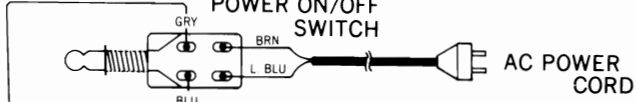

POWER TRANSFORMER

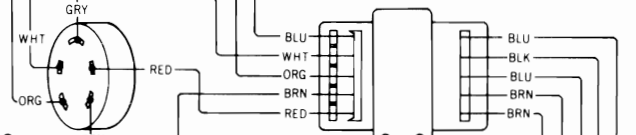

S12: VOLTAGE SELECT SWITCH

※For Australia.

EXPLODED VIEWS

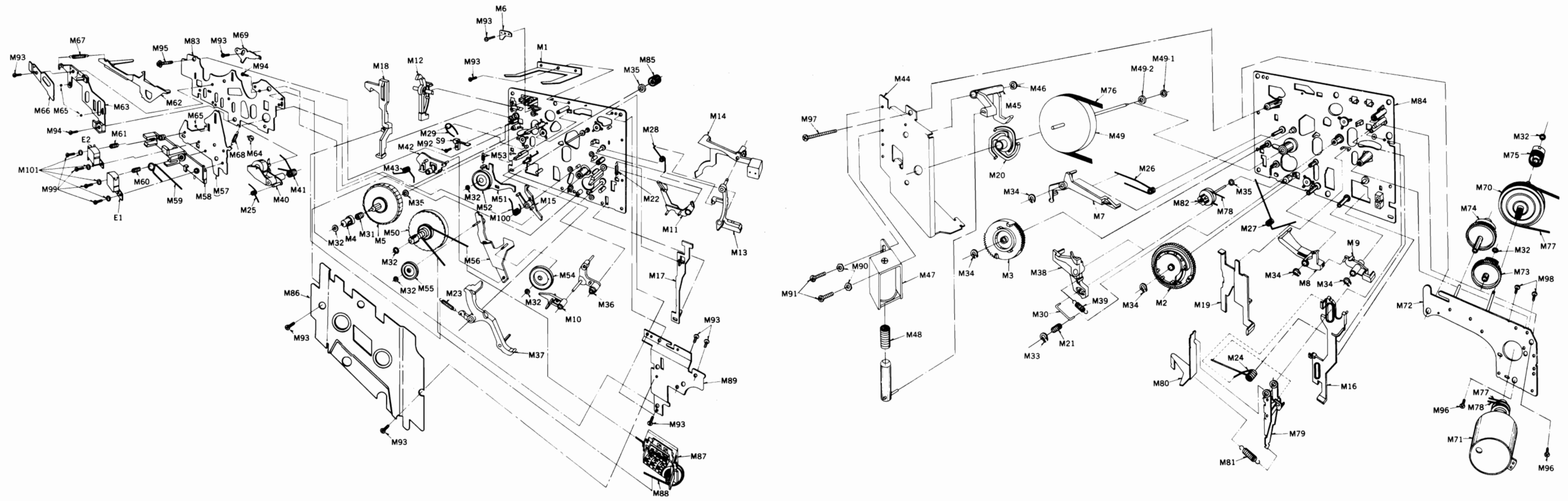

Ref. No.	Part No.	Part Name & Description	Ref. No.	Part No.	Part Name & Description	Ref. No.	Part No.	Part Name & Description	Ref. No.	Part No.	Part Name & Description	Ref. No.	Part No.	Part Name & Description
MECHANICAL PARTS														
M1	QBP1874	Cassette Pressure Spring	M21	QBC1357	Lock Pin Pressure Spring	M42	QML3588	Fast Forward Lever	M62	QML3591	Brake Arm	M82	QXP0607	Fast Forward Connection Pulley Assembly
M2	QDG1201	Main Gear	M22	QBT1682	Auto-Stop Connection Rod Spring	M43	QBN1748	Fast Forward Spring	M63	QMZ1240	Sub Head Base Plate	M83	QMK1838	Upper Base Plate
M3	QDG1202	Sub Gear	M23	QBT1894	Main Lever Spring	M44	QXA1042	Plunger Angle Assembly	M64	QMN2550	Roller	M84	QXK2276	Lower Base Plate
M4	QMB1336	Supply Reel Table Hub	M24	QBN1739	Selection Lever Spring	M45	QML3607	Pause Driving Lever	M65	QDK1017	Steel Ball 2φ	M85	QDP1828	Fast Forward Pulley
M5	QDR1139	Supply Reel Table	M25	QBN1742	Pressure Roller Release Spring	M46	XUC3FT	Stop Ring 3φ	M66	QBP1873	Head Base Plate Pressure Spring	M86	QXH0327	Chassis Cover Assembly
M6	QMF2118	Fast Forward Arm Bracket	M26	QBN1744	Sub Gear Spring	M47	QME0157	Plunger	M67	QBT1597	Brake Arm Spring	M87	QXC0060	Tape Counter
M7	QML3581	Sub Control Lever	M27	QBN1745	Main Gear Spring	M48	QBC1358	Plunger Release Spring	M68	QBT1892	Head Release Spring	M88	QDB0240	Counter Belt
M8	QML3583	Main Control Lever	M28	QBN1746	Auto-Stop Lever Spring	M49	QXF0164	Flywheel Assembly	M69	QMA3858	Pressure Roller Adjustment Plate	M89	QMA3860	Counter Angle
M9	QML3584	Record Operation Lever	M29	QBN1747	Connection Spring	M49-1	QBW2049	Poly Washer	M70	QXG1047	Takeup Gear Assembly	M90	XWC3B	Washer 3φ
M10	QML3586	Head Base Plate Lift Lever	M30	QBS1128	Lock Pin	M49-2	QBW2026	Washer	M71	QXU0170	Motor Assembly	M91	XSN3+6S	Screw φ3×6
M11	QML3594	Auto-Stop Release Arm	M31	QBC1306	Reel Table Spring	M50	QXD1143	Takeup Reel Table Assembly	M72	QXK2286	Sub Chassis Assembly	M92	XTN2+6B	Tapping Screw φ2.6×6
M12	QML3603	Erase Safety Lever	M32	QBW2008	Poly Washer 2φ	M51	QXL1382	Idle Lever Assembly	M73	QDG1199	Auto-Stop Gear	M93	XTN26+6B	Tapping Screw φ2.6×6
M13	QML3604	Auto-Stop Driving Lever	M33	XUB4FT	Stop Ring 4φ	M52	QXI0111	Takeup Idler Assembly	M74	QDG1200	Cam Gear	M94	XTN26+10B	Tapping Screw φ2.6×10
M14	QML3605	Auto-Stop Detection Lever	M34	XUB3FT	Stop Ring 3φ	M53	QBT1893	Takeup Idler Spring	M75	QDP1823	Connection Pulley	M95	XTN26+12B	Tapping Screw φ2.6×12
M15	QML3592	Change Lever	M35	QBW2012	Poly Washer	M54	QXI0113	Fast Forward Idler Assembly	M76	QDB0281	Capstan Belt	M96	XTN3+10B	Tapping Screw φ3×10
M16	QMR1820	Record Rod	M36	QXL1354	Sub Lever Assembly	M55	QXI0112	Rewind Idler Assembly	M77	QDB0273	Fast Forward Belt	M97	XTN3+24B	Tapping Screw φ3×24
M17	QMR1821	Auto-Stop Connection Rod	M37	QXL1355	Main Lever Assembly	M56	QXL1383	Fast Forward Arm Assembly	M78	QDB0274	Takeup Belt	M98	XSN26+3S	Screw φ2.6×3
M18	QMR1822	Eject Rod	M38	QML3582	Pause Lock Lever	M57	QMK1840	Head Base Plate	M79	QXL1360	Record/Playback Selection Arm Assembly	M99	XSN2+10	Screw φ2×10
M19	QMR1824	Control Rod	M39	QBT1896	Lever Release Spring	M58	QML2141	Head Spacer	M80	QML3580	Record/Playback Selection Lever	M100	QBN1741	Change Lever Spring
M20	QMZ1239	Flywheel Thrust Retainer	M40	QXL1381	Pressure Roller Assembly	M59	QBN1740	Head Pressure Spring	M81	QBT1895	Record/Playback Selection Lever Spring	M101	XWA2	Washer 2φ
			M41	QBN1743	Pressure Roller Spring	M60	QBC1278	Head Spring						
						M61	QBCA0008	"						

SPECIFICATIONS

Pressure of pressure roller	350 ± 50 gr
Takeup tension • Use cassette torque meter ... QZZSRKCT	45 +15 -10 gr-cm
Wow and flutter; (JIS) • Use test tape ... QZZCWAT	Less than 0.06% (WRMS)

CABINET PARTS

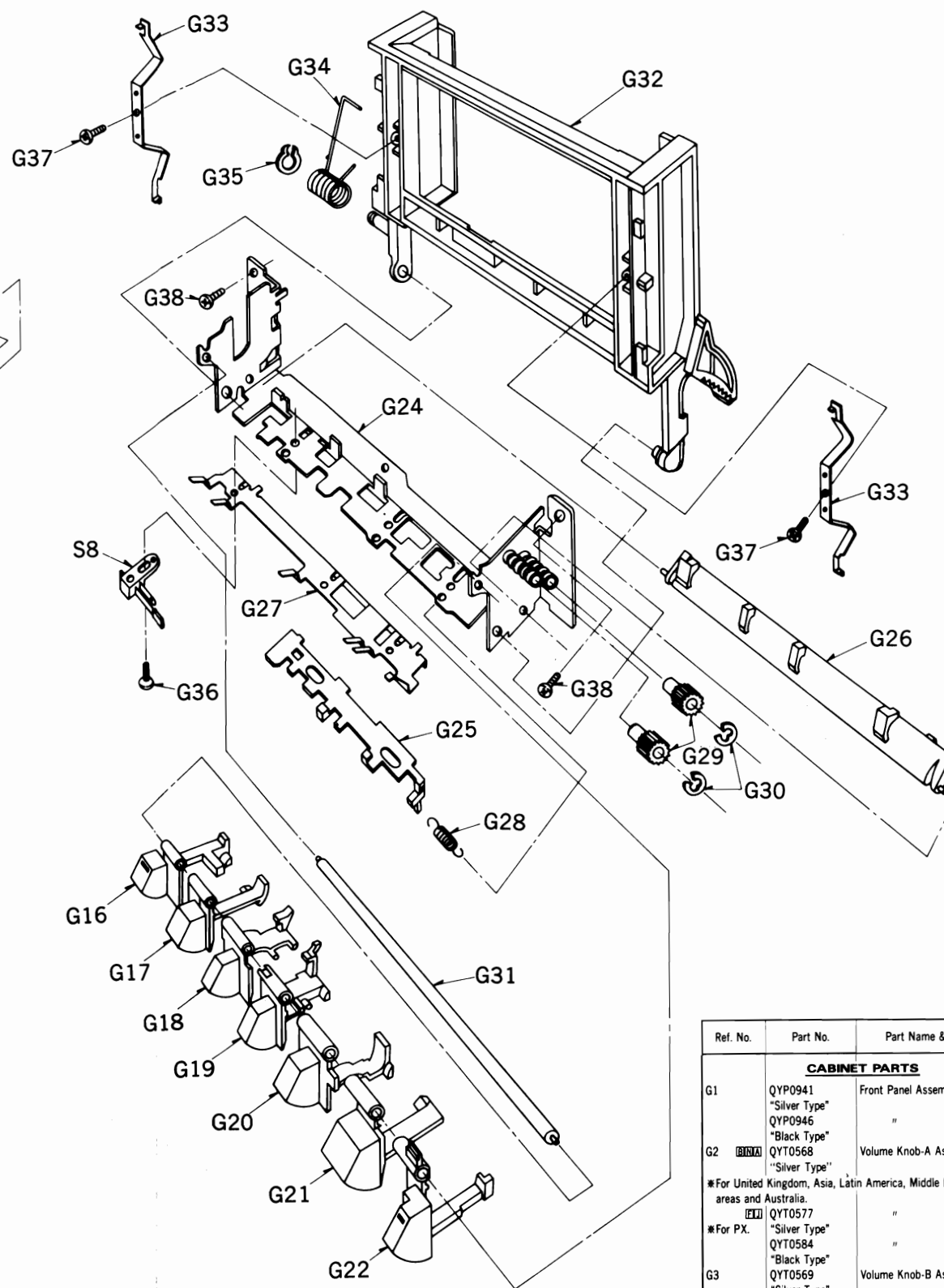
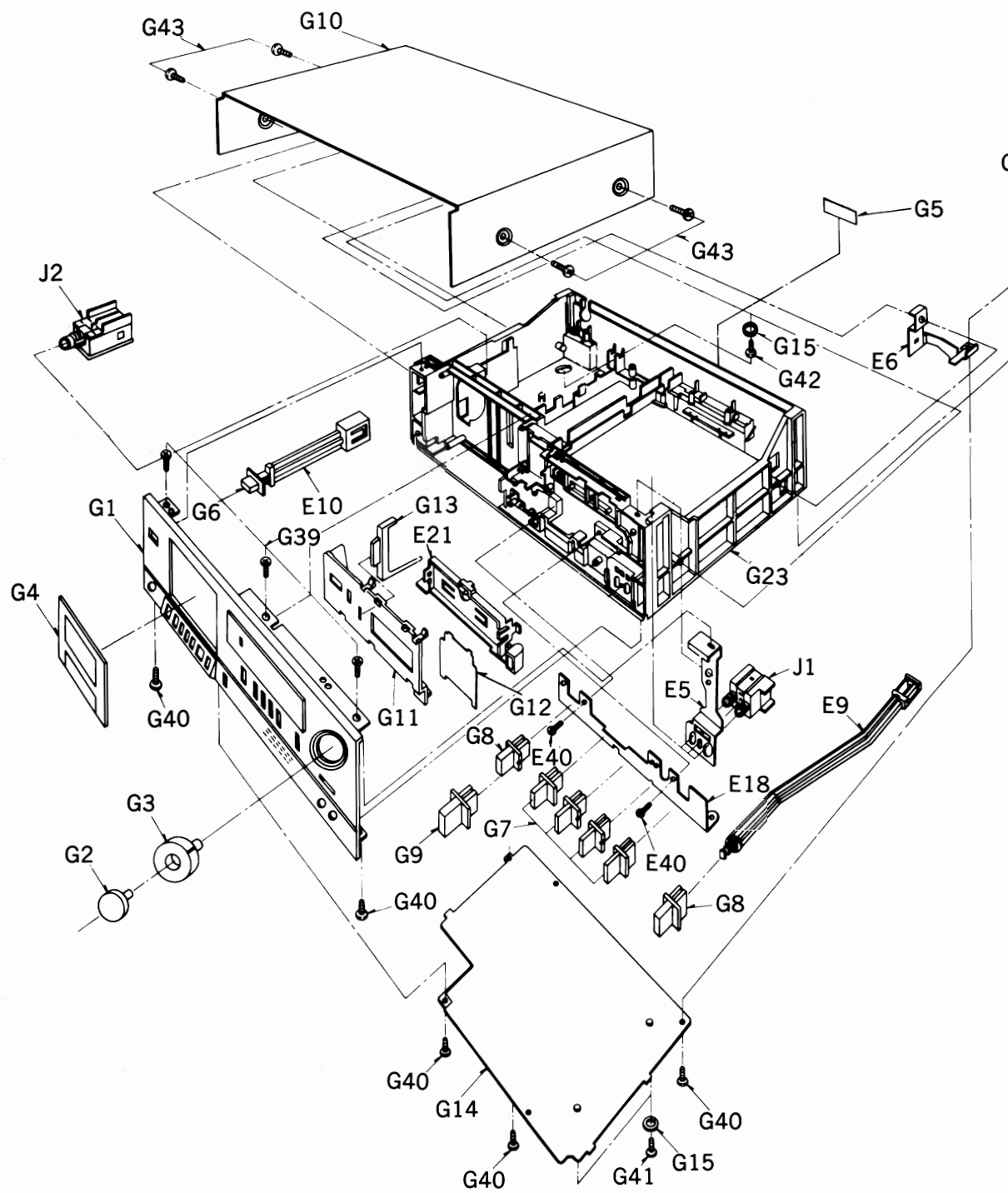

Ref. No.	Part No.	Part Name & Description
G5	QGS2765	Main Name Plate
	QGS2790	*For United Kingdom and Australia.
	QGS2792	*For Asia, Latin America, Middle East and Africa areas.
G6	QGO1692	Power Button
	QGO1692K	"Silver Type"
	QGO1693	"Black Type"
G7	QGO1693K	Tape Select Button
	QGO1694	"Silver Type"
	QGO1694K	"Black Type"
G8	QGO1695	Tape Select Button
	QGC1182	Dolby NR/Input Select Button
	QGC1182K	"Silver Type"
	QGC1182K	"Black Type"
G9	QGC1182	Rec Mute Button
G10	QGC1182	Case Cover
	QGC1182K	"Silver Type"
	QGC1182K	"Black Type"
G11	QGK3008	Meter Cover
	QGK3039	"Silver Type"
	QGK3039	"Black Type"
G12	QGL1142	Filter
G13	QGL1143	LED Holder
G14	QGC1183	Bottom Cover
G15	QKA1076	Rubber Foot
G16	QXL1363	Eject Button Assembly
G17	QXL1364	Record Button Assembly
G18	QXL1365	Rewind Button Assembly
G19	QXL1366	Fast Forward Button Assembly
G20	QXL1367	Playback Button Assembly
G21	QXL1368	Stop Button Assembly
G22	QXL1369	Pause Button Assembly
G23	QKM1414K	Main Case
G24	QXA1044	Operation Button Angle Assembly
G25	QMR1823	Obstruction Rod
G26	QML3593	Lock Arm
G27	QBP1875	Operation Lever Spring
G28	QBT1597	Obstruction Rod Spring
G29	QDG1102	Holder Gear
G30	XUC4FT	Stop Ring 4φ
G31	QMN2554	Operation Lever Shaft
G32	QKF6015K	Cassette Holder
G33	QBP1771	Holder Spring
G34	QBN1749	Eject Spring
G35	XUB5FT	Stop Ring 5φ
G36	XTN2+6B	Tapping Screw φ2×6
G37	XTN26+5B	Tapping Screw φ2.6×5
G38	XTN26+6B	Tapping Screw φ2.6×6
G39	XTS3+10B	Tapping Screw φ3×10
G40	XTN3+10B	Tapping Screw φ3×10
G41	XTN4+8S	Tapping Screw φ4×8
G42	XTN4+10B	Tapping Screw φ4×10
G43	XTN4+10BFN	Tapping Screw φ4×10
	XTN4+10BFZ	"Silver Type"
	XTN4+10BFZ	"Black Type"
ACCESSORIES		
A1	RP023A	Connection Cord
A2	QQT2789	Instruction Book
	QQT2788	*For United Kingdom and Australia.
	QQT2787	*For Asia, Latin America, Middle East and Africa areas.
	QQT2787	*For PX.
A3	QFTC30S011T2	Demonstration Tape
	QJP0603S	*For Asia, Latin America, Middle East, Africa areas and Australia.
A4	QJP0603S	AC Plug Adaptor
	QJP0603S	*For Asia, Latin America, Middle East and Africa areas.
CABINET PARTS		
G1	QYP0941	Front Panel Assembly
	QYP0946	"Silver Type"
	QYT0568	"Black Type"
G2	QYT0568	Volume Knob-A Assembly
	QYP0941	"Silver Type"
	QYT0577	"Black Type"
	QYT0584	"Silver Type"
	QYT0569	"Black Type"
G3	QYT0585	Volume Knob-B Assembly
	QYT0585	"Silver Type"
	QYT0585	"Black Type"
G4	QYF0409	Cassette Lid Assembly
	QYF0430	"Silver Type"
	QYF0430	"Black Type"
PACKINGS		
P1	QPN3968	Inside Carton
	QPN4005	*For United Kingdom.
	QPN3997	*For Asia, Latin America, Middle East and Africa areas.
	QPN3992	*For Australia.
	QPA0532	*For PX.
P2	QPA0533	Cushion-L
P3	QPG1985	Cushion-R
P4	QPS0434	Pad
	QPA0543	*For United Kingdom, Middle East, Africa areas and Australia.
P5	QPA0543	Spacer
	QPA0562	*For United Kingdom and PX.
	XZB40X60A02	*For Australia.
P6	XZB40X60A02	Poly Bag

Ref. No.	Part No.	Part Name & Description
G1	QYP0941	Front Panel Assembly
	QYP0946	"Silver Type"
	QYT0568	"Black Type"
G2	QYT0568	Volume Knob-A Assembly
	QYP0941	"Silver Type"
	QYT0577	"Black Type"
	QYT0584	"Silver Type"
	QYT0569	"Black Type"
G3	QYT0585	Volume Knob-B Assembly
	QYT0585	"Silver Type"
	QYT0585	"Black Type"
G4	QYF0409	Cassette Lid Assembly
	QYF0430	"Silver Type"
	QYF0430	"Black Type"

RS-M24 DEUTSCH

Messungen und Einstellungen

Anm.: Für gute Meßbedingungen sorgen. Falls nicht anders angegeben, die Schalter und Regler in folgende Positionen stellen.

- Für saubere Köpfe sorgen.
- Für saubere Tonwelle und Andruckrolle sorgen.
- Auf normale Raumtemperatur achten: 20±5°C
- Dolby-Schalter: Aus.
- Bandwahl Schalter: Normal-Position.
- Spitzenwertschalter: LINE.
- Eingangsregler: MAX.

Gegenstand	Messung und Einstellung
Ⓐ Tonkopf-Positionierung Bedingung * Wiedergabe und Pause	Die Tonkopf-Positionierplatte dient zum Einstellen des Kontakts zwischen Tonkopf und Band während der Betriebszustände „Cue“ und „Review“. <ol style="list-style-type: none"> 1. Die Wiedergabetaste PLAY und die Pausetaste drücken. 2. Den Abstand zwischen der Andruckrolle und der Tonwelle messen. Sollwert: 0,5±0,3cm 3. Falls der Meßwert außerhalb des Toleranzbereichs liegt, die Schraube A lösen und die Tonkopf-Positionierplatte in Pfeilrichtung B schieben, um den Kopfkontakt einzustellen.
Ⓑ Senkrechtstellen des Kopfes Bedingung * Wiedergabe Meßgerät: * Röhrenvoltmeter * Oszillograf * Testband...QZZCFM	Justage des Aufnahme/Wiedergabekopfes <ol style="list-style-type: none"> 1. Den Meßaufbau zeigt Fig. 11. 2. Testband (QZZCFM, 8kHz) wiedergeben. 3. Einstellschraube (B) (Fig. 12) auf maximale Ausgangsspannung einstellen. 4. Beide Kanäle überprüfen und auf gleiche Ausgangsspannung einstellen. 5. Nach dem Abgleich Einstellschraube mit Lack sichern.
Ⓒ Bandgeschwindigkeit Bedingung * Wiedergabe Meßgerät: * Elektronischer Digitalzähler * Testband...QZZCWAT	Genauigkeit der Bandgeschwindigkeit <ol style="list-style-type: none"> 1. Den Meßaufbau zeigt Fig. 13. 2. Testband (QZZCWAT 3000Hz) wiedergeben und Ausgangssignal dem Zähler zuführen. 3. Frequenz messen. 4. Beträgt die auf dem Testband aufgezeichnete Frequenz 3000Hz, so ergibt sich die Genauigkeit nach folgender Formel: Genauigkeit der Bandgeschwindigkeit = $\frac{f-3000}{3000} \times 100(\%)$ worin f die gemessene Frequenz ist. 5. Die Messung soll im mittleren Teil des Bandes erfolgen. <p style="text-align: center;">NORMALWERT: ±1,5%</p> Einstellung: <ol style="list-style-type: none"> 1. Den mittleren Teil des Testbandes wiedergeben. 2,3. Die Einstellschraube VR Vgl Fig.27 so verstellen, daß eine Frequenz von 3000Hz angezeigt wird. Schwankung der Bandgeschwindigkeit: Messung, wie oben beschrieben für Anfang, mittleren Teil und Ende des Testbandes wiederholen und Schwankung wie folgt bestimmen: $\text{Schwankung} = \frac{f_1 - f_2}{3000} \times 100(\%)$ f ₁ = Maximalwert f ₂ = Minimalwert <p style="text-align: center;">NORMALWERT: 1%</p>

Gegenstand	Messung und Einstellung
Ⓓ Frequenzgang bei Wiedergabe Bedingung: * Wiedergabe Meßgerät: * Röhrenvoltmeter * Oszillograf * Testband...QZZCFM	<ol style="list-style-type: none"> 1. Den Meßaufbau zeigt Fig. 11, jedoch ist jetzt das Testband QZZCFM zu verwenden. 2. Gerät auf "wiedergabe" schalten. 3. Frequenzgang-Testband QZZCFM wiedergeben. 4. Ausgangsspannungen bei 12,5kHz, 10kHz, 8kHz, 4kHz, 1kHz, 250Hz, 125Hz und 63Hz mit Ausgangsspannung der Standard Frequenz 315Hz vergleichen. 5. Messungen an beiden Kanälen durchführen. 6. Prüfen, ob die Werte innerhalb der in Fig. 14 dargestellten Kurven liegen.
Ⓔ Wiedergabe-Verstärkung Bedingung * Wiedergabe Meßgerät: * Röhrenvoltmeter * Oszillograf * Testband...QZZCFM	<ol style="list-style-type: none"> 1. Den Meßaufbau zeigt Fig. 11. 2. Standard-Frequenz (QZZCFM 315Hz) vom Testband wiedergeben und Ausgangsspannung messen. 3. Messung an beiden Kanälen durchführen. <p style="text-align: center;">NORMALWERT: Ungefähr 0,7V</p> Einstellung: <ol style="list-style-type: none"> 1. Abweichungen können durch Abgleich von VR3 (Linker Kanal) und VR4 (Rechter Kanal) (S. Fig.27) korrigiert werden. 2. Nach erfolgtem Abgleich ist der Frequenzgang bei Wiedergabe erneut zu kontrollieren.
Ⓕ Störstrahlung der Vormagnetisierung Bedingung: * Aufnahme Meßgerät: * Elektronisches Voltmeter * Oszillograf	<ol style="list-style-type: none"> 1. Den Meßaufbau zeigt Fig. 15. 2. Gerät auf Aufnahme schalten. 3. Sperrkreisspulen L3 (Linker Kanal) und L4 (Rechter Kanal) so abgleichen daß der Meßwert minimal wird. (S. Fig. 27). 4. Beide Kanäle abgleichen.
Ⓖ Löschstrom Bedingung: * Aufnahme * Band Schalter ...Metal position ...CrO ₂ position ...Fe-Cr position ...Normal position Meßgerät: * Röhrenvoltmeter * Oszillograf	<ol style="list-style-type: none"> 1. Den Meßaufbau zeigt Fig. 16. 2. Die Aufnahme- und Pausetaste drücken. 3. Den Bandwahlschalter in die „Metal“-Position stellen. 4. Löschstrom nach folgender Formel ermitteln: $\text{Löschstrom (A)} = \frac{\text{Die Spannung über beide Enden von R301}}{1 \text{ (Ohm)}}$ <p style="text-align: center;">NORMALWERT: 110±10mA (Metal position)</p> <ol style="list-style-type: none"> 5. Abweichungen können durch Abgleich von VR301 korrigiert werden. 6. Den Bandwahlschalter in jede Position stellen. 7. Überprüfen, ob der Meßwert im vorgeschriebenen Bereich liegt. <p style="text-align: center;">Ungefähr 65mA (CrO₂ position) NORMALWERT: Ungefähr 55mA (Fe-Cr position) Ungefähr 50mA (Normal position)</p>

Gegenstand	Messung und Einstellung
Ⓗ Vormagnetisierung Bedingung * Aufnahme * Band Schalter ...Metal position ...Normal position ...Fe-Cr position ...CrO ₂ position Meßgerät: * Röhrenvoltmeter * Oszillograf	A. Messung und Abstimmung für der M <ol style="list-style-type: none"> 1. Den Meßaufbau zeigt Fig. 17. 2. Die Aufnahme- und Pausetaste drücken. 3. Den Bandwahlschalter in die „Metal“-Position stellen. 4. Spannung vom Röhrenvoltmeter ablesen und mit folgender Formel berechnen: $\text{Vormagnetisierungsstrom (A)} = \frac{\text{Spannung am Röhren}}{10 \text{ (Ohm)}}$ <p style="text-align: center;">NORMALWERT: 800±20µA</p> <ol style="list-style-type: none"> 5. Falls der gemessene Wert nicht dem in Fig. 17 angegebenen VR abgleiche. VR303 (L-ch), VR301 (R-ch). B. Messung und Abstimmung für der N <ol style="list-style-type: none"> 1. Den Bandwahlschalter in die „Normal“-Position stellen. 2. Überprüfen, ob der Meßwert im vorgeschriebenen Bereich liegt. <p style="text-align: center;">NORMALWERT: Ungefähr 0,7V</p> <ol style="list-style-type: none"> 3. Falls der gemessene Wert nicht dem in Fig. 17 angegebenen VR abgleichen. VR302 (L-ch), VR304 (R-ch). C. Messung für die Fe-Cr Band CrO₂ Ba <ol style="list-style-type: none"> 1. Den Bandwahlschalter in jede Position stellen. 2. Überprüfen, ob der Meßwert im vorgeschriebenen Bereich liegt. <p style="text-align: center;">NORMALWERT: Ungefähr 0,7V</p>
Ⓙ Fluoreszenzmeter Bedingung: * Aufnahme * Eingangsregler...Max. * Bandwahlschalter ...Normal position Meßgerät: * Röhrenvoltmeter * NF-Generator * Abschwächer	<ol style="list-style-type: none"> 1. Den Meßaufbau zeigt Fig. 22. 2. Wie aus Fig. 9 ersichtlich, hört der auf, wenn der Kollektor des Q403 mit dem Bandwahlschalter verbunden ist. 3. Signal vor 1kHz (-24dB) an die Line-In-Buchse der Aufnahme- und Pausetaste drücken. 4. ATT so abstimmen, daß der Ausgangspegel der Aufnahme- und Pausetaste als Standardpegel bezeichnet wird (Der Ausgangspegel der Aufnahme- und Pausetaste ist als Standardpegel bezeichnet). 5. Justierung auf „-20dB“. A. Den Abschwächer so einstellen, daß der Ausgangspegel der Aufnahme- und Pausetaste -20dB des Standard-Aufnahmepegels entspricht. B. VR401 so abgleichen, daß im Bereich der Aufnahme- und Pausetaste -20dB aufleuchtet (NUR bei Fe-Cr position) (S. Fig. 9) 6. Justierung auf „0dB“. A. ATT so abstimmen, daß der Ausgangspegel der Aufnahme- und Pausetaste 0dB des Standardpegels entspricht. B. VR402 so abgleichen, daß im Bereich der Aufnahme- und Pausetaste 0dB des Standardpegels entspricht (S. Fig. 9) 7. Die Anleitungsschritte 5 bis 6 zweimal wiederholen. 8. Die ATT einstellen; kontrollieren, ob der Ausgangspegel der Aufnahme- und Pausetaste 10dB über dem Standardpegel ist. (S. Fig. 21)

	Messung und Einstellung
	<ol style="list-style-type: none"> Den Meßaufbau zeigt Fig. 11, jedoch ist jetzt das Testband QZZCFM zu verwenden. Gerät auf "wiedergabe" schalten. Frequenzgang-Testband QZZCFM wiedergeben. Ausgangsspannungen bei 12,5kHz, 10kHz, 8kHz, 4kHz, 1kHz, 250Hz, 125Hz und 63Hz mit Ausgangsspannung der Standard Frequenz 315Hz vergleichen. Messungen an beiden Kanälen durchführen. Prüfen, ob die Werte innerhalb der in Fig. 14 dargestellten Kurven liegen.
ng	<ol style="list-style-type: none"> Den Meßaufbau zeigt Fig. 11. Standard-Frequenz (QZZCFM 315Hz) vom Testband wiedergeben und Ausgangsspannung messen. Messung an beiden Kanälen durchführen. <p style="text-align: center;">NORMALWERT: Ungefähr 0,7V</p> <p>Einstellung:</p> <ol style="list-style-type: none"> Abweichungen können durch Abgleich von VR3 (Linker Kanal) und VR4 (Rechter Kanal) (S. Fig.27) korrigiert werden. Nach erfolgtem Abgleich ist der Frequenzgang bei Wiedergabe erneut zu kontrollieren.
r	<ol style="list-style-type: none"> Den Meßaufbau zeigt Fig. 15. Gerät auf Aufnahme schalten. Sperrkreisspulen L3 (Linker Kanal) und L4 (Rechter Kanal) so abgleichen daß der Meßwert minimal wird. (S. Fig. 27). Beide Kanäle abgleichen.
	<ol style="list-style-type: none"> Den Meßaufbau zeigt Fig. 16. Die Aufnahme- und Pausentaste drücken. Den Bandwahlschalter in die „Metal“-Position stellen. Löschstrom nach folgender Formel ermitteln: $\text{Löschstrom (A)} = \frac{\text{Die Spannung über beide Enden von R301}}{1 \text{ (Ohm)}}$ <p style="text-align: center;">NORMALWERT: 110±10mA (Metal position)</p> <ol style="list-style-type: none"> Abweichungen können durch Abgleich von VR301 korrigiert werden. Den Bandwahlschalter in jede Position stellen. Überprüfen, ob der Meßwert im vorgeschriebenen Bereich liegt. <p style="text-align: center;">Ungefähr 65mA (CrO₂ position) NORMALWERT: Ungefähr 55mA (Fe-Cr position) Ungefähr 50mA (Normal position)</p>

Gegenstand	Messung und Einstellung
<p>Ⓜ Vormagnetisierung</p> <p>Bedingung</p> <ul style="list-style-type: none"> * Aufnahme * Band Schalter ...Metal position ...Normal position ...Fe-Cr position ...CrO₂ position <p>Meßgerät:</p> <ul style="list-style-type: none"> * Röhrenvoltmeter * Oszillograf 	<p>A. Messung und Abstimmung für der Metal-Band-Position.</p> <ol style="list-style-type: none"> Den Meßaufbau zeigt Fig. 17. Die Aufnahme- und Pausentaste drücken. Den Bandwahlschalter in die „Metal“-Position stellen. Spannung vom Röhrenvoltmeter ablesen und Vormagnetisierungsstrom nach folgender Formel berechnen: $\text{Vormagnetisierungsstrom (A)} = \frac{\text{Spannung am Röhrenvoltmeter (V)}}{10 \text{ (Ohm)}}$ <p style="text-align: center;">NORMALWERT: 800±20µA (Metal position)</p> <ol style="list-style-type: none"> Falls der gemessene Wert nicht der Toleranz liegt, die folgenden VR abgleiche. VR303 (L-ch), VR301 (R-ch). <p>B. Messung und Abstimmung für der Normal-Band-Position.</p> <ol style="list-style-type: none"> Den Band wahlschalter in die "Normal"-Position stellen. Über prüfen, ob der Meßwert im vorgeschriebenen Bereich liegt. <p style="text-align: center;">NORMALWERT: Ungefähr 370µA (Normal position)</p> <ol style="list-style-type: none"> Falls der gemessene Wert nicht der Toleranz liegt, die folgenden VR abgleichen. VR302 (L-ch), VR304 (R-ch). <p>C. Messung für die Fe-Cr Band CrO₂ Band Position.</p> <ol style="list-style-type: none"> Den Bandwahlschalter in jede Position stellen. Überprüfen, ob der Meßwert im vorgeschriebenen Bereich liegt. <p style="text-align: center;">NORMALWERT: Ungefähr 390µA (Fe-Cr position) Ungefähr 500µA (CrO₂ position)</p>
<p>Ⓛ Fluorezenzmeter</p> <p>Bedingung:</p> <ul style="list-style-type: none"> * Aufnahme * Eingangsregler...Max. * Bandwahlschalter ...Normal position <p>Meßgerät:</p> <ul style="list-style-type: none"> * Röhrenvoltmeter * NF-Generator * Abschwächer 	<ol style="list-style-type: none"> Den Meßaufbau zeigt Fig. 22. Wie aus Fig. 9 ersichtlich, hört der astabile, aus den Transistoren Q304 und Q404 bestehende Multivibrator zu schwingen auf, wenn der kollektor des Q403 mit Mass verbunden wird. Signal vor 1kHz (-24dB) an die Line IN-Buchse eingeben und die Aufnahmetaste drücken. ATT so abstimmen, daß der Ausgangspegel an der LINE OUT-Buchse 0,7V wird (Der Eingangspegel in dieser Stellung wird als Standardpegel bezeichnet). Justierung auf „-20dB“. A. Den Abschwächer so einstellen, daß der Eingangspegel -20dB des Stand-Aufnahmepegels beträgt. B. VR401 so abgleichen, daß im Bereich von -20±0,8dB das Segment -20dB aufleuchtet (NUR LINKER KANAL). (S. Fig. 9) Justierung auf "0dB". A. ATT so abstimmen, daß der Ausgangspegel an der LINE OUT-Buchse 0,7V wird. B. VR402 so abgleichen, daß im Bereich von ±0,2dB um den Standardpegel das Segment +1dB aufleuchtet. (S. Fig. 20) Die Anleitungsschritte 5 bis 6 zweimal wiederholen. Die ATT einstellen; kontrollieren, ob alle Segmente aufleuchten, wenn der Eingangspegel 10dB höher als der Standardpegel ist. (S. Fig. 21)

Gegenstand	Messung und Einstellung
<p>Ⓞ Dolby-Schaltung</p> <p>Bedingung:</p> <ul style="list-style-type: none"> * Aufnahme * Eingangsregler...Max. <p>Meßgerät:</p> <ul style="list-style-type: none"> * Röhrenvoltmeter * NF-Generator * Abschwächer * Oszillograf 	<ol style="list-style-type: none"> Gerät in Stellung "Aufnahme" betreiben und Dolby-Schalter ausschalten. Dem NF-Eingang ein 5kHz-Signal zuführen, daß an TP9 (Linker Kanal) und TP10 (Rechter Kanal) -34,5dB erhalten werden. Prüfen, ob das Signal bei eingeschaltetem Dolby-Schalter um 8 (±2,5) dB größer ist als bei ausgeschaltetem Dolby-Schalter.
<p>Ⓚ Gesamt-Verstärkung</p> <p>Bedingung</p> <ul style="list-style-type: none"> * Aufnahme und Wiedergabe * NF-Eingangsregler...Max. * Standard-Eingangspegel Mikrofon -72±4dB NF-Eingang -24±4dB <p>Meßgerät:</p> <ul style="list-style-type: none"> * NF-Generator * Röhrenvoltmeter * Abschwächer * Oszillograf * Testband (Leerband) QZZCRA für Normal 	<ol style="list-style-type: none"> Den Meßaufbau zeigt Fig. 22. Gerät auf "Aufnahme", und Bandwahlschalter auf Normal Position stellen. Über den Abschwächer 1kHz aus dem NF-Generator (-24dB) dem NF-Eingang zuführen. Den Abschwächer so einstellen, daß am NF-Ausgang stehen 0,7V stehen. Dieses Signal auf Testband (QZZCRA) aufnehmen. Diese Aufnahme wiedergeben und prüfen, ob am NF-Ausgang 0,7V stehen. Ist des nicht der Fall, so sind VR5 (Linker Kanal) und VR6 (Rechter Kanal) entsprechend abzugleichen (S. Fig. 9), Ab Punkt 2 wiederholen.
<p>Ⓛ Gesamt-frequenzgang</p> <p>Bedingung</p> <ul style="list-style-type: none"> * Aufnahme und Wiedergabe * Eingangsregler...Max. * Band Schalter ...Normal position ...Fe-Cr position ...CrO₂ position ...Metal position <p>Meßgerät:</p> <ul style="list-style-type: none"> * Röhrenvoltmeter * NF-Generator * Abschwächer * Testband (Leerband) QZZCRA für Normal QZZCRY für Fe-Cr QZZCRX für CrO₂ QZZCRZ für Metal 	<p>Anm.: Vor Messung und Abgleich des Gesamtfrequenzganges ist sicherzustellen, daß der Frequenzgang bei Wiedergabe korrekt ist (Vgl. entspr. Abschnitt).</p> <ol style="list-style-type: none"> Den Meßaufbau zeigt Fig. 22. Testband (QZZCRA) in das Cassettenfach einsetzen. Gerät auf „Aufnahme“ und Bandwahlschalter auf „Normal“ schalten. 1kHz vom NF-Generator über den Abschwächer dem NF-Eingang zuführen. Den Abschwächer so einstellen, daß der Eingangspegel -20dB des Stand-Aufnahmepegels beträgt. Zu diesem Zeitpunkt beträgt der Ausgangspegel 0,07V. Bei dem gleichen Pegel sind die Frequenzen 30Hz, 70Hz, 200Hz, 1kHz, 4kHz, 8kHz, 10kHz, 12kHz und 13kHz (14kHz für CrO₂ band oder Fe-Cr band, 15kHz für Metal band) aufzunehmen. Diese Aufnahme wiedergeben und dabei die Abweichungen der Pegel der einzelnen Frequenzen vom 1kHz-Pegel in dB bestimmen. Überzeugen Sie sich, ob der gemessene Wert in dem angegebenen Bereich liegt. (Siehe Diagramm für die Frequenzgänge von Normal, Fig. 23). Falls der gemessene Wert nicht der Toleranz liegt. Die folgenden VR abgleichen. VR302 (L-ch), VR304 (R-ch) <p>Anm.:</p> <ul style="list-style-type: none"> Mit VR302 den linken Kanal genauso abgleichen. Um den linken Kanal weiter einzustellen, VR303 benutzen. Wenn der Frequenzgang zwischen dem mittleren und hohen Frequenzgang höher als der Standardwert wird, wie durch die feste Linie in Fig. 32 angezeigt, die Vormagnetisierungsstrom-Abstimmung durchführen. Für die Messung des Vormagnetisierungsstromes sei auf den Abschnitt „Vormagnetisierung“ hingewiesen. <ol style="list-style-type: none"> Ab Punkt 2 wiederholen. Nacheinander das Fe-Cr (QZZCRY), CrO₂ (QZZCRX) und Metal (QZZCRZ) Testband verwenden. Den Bandwahlschalter in jede Position stellen. Auf die gleiche Weise wie zuvor messen. Überzeugen Sie sich, ob der gemessene Wert in dem angegebenen Bereich liegt. (Siehe Diagramm für die Frequenzgänge von Fe-Cr, CrO₂ und Metal bande Fig. 24 und 25.)

RS-M24 FRANCAIS

MESURES ET REGLAGE

NOTA:
Pour garder l'appareil en bon état de marche, positionner les commutateurs à levier et les commandes dans les positions suivantes, sauf indication contraire.

- Vérifiez que les têtes soient propres.
- Vérifiez que le cabestan et le galet presseur soient propres.
- Température ambiante admissible: 20±5°C.
- Sélecteur de Dolby: OUT.
- Sélecteur de bande: position normale.
- Commutateur de test de crête: LINE.
- Commande de niveau: MAX.

SECTION	MESURES ET REGLAGES
Ⓐ Réglage de la position de la tête CONDITION * Le mode de lecture et pause	Il y a une plaque de réglage de la tête pour ajuster le contact de bande de la tête en mode de repérage avant ou arrière. 1. Appuyer sur le bouton de lecture (PLAY) et le bouton de pause. 2. Mesurer l'espace qui sépare le galet presseur du cabestan. Valeur standard: 0.5±0.3cm 3. Si la valeur mesurée se trouve hors tolérances, desserrer la vis A, et glisser la plaque de réglage de la tête dans la direction de la flèche B pour effectuer le réglage.
Ⓔ Azimutage de tête CONDITION * Position lecture Equipement: * Voltmètre électronique * Oscilloscope * Bande étalon (azimutage)...QZZCFM	Réglage de la tête d'enregistrement/lecture 1. Branchez les appareils comme ci-dessous (Voir fig. 11). 2. Lisez la bande étalon d'azimutage (QZZCFM, 8kHz). 3. Réglez la vis d'orientation (B) fig. 12 de la tête d'enregistrement/lecture pour obtenir le niveau maximal à la sortie LINE OUT. 4. Mesurez les deux canaux, et ajustez les niveaux à égalité de tension de sortie. 5. Après réglage, bloquez la vis par une goutte de vernis.
Ⓒ Vitesse de défilement CONDITION * Position lecture Equipement: * Compteur électronique numérique ou fréquencemètre numérique * Bande étalon...QZZCWAT	Précision de la vitesse de défilement 1. Branchez les appareils comme ci-dessous. (Voir fig. 13). 2. Lisez la bande étalon (QZZCWAT, 3000Hz) et appliquez le signal de sortie au fréquencemètre. 3. Mesurez sa fréquence. 4. Sur la base de 3000Hz, déterminez la valeur à l'aide de la formule. $\text{Précision de vitesse} = \frac{f-3000}{3000} \times 100(\%)$ avec f = valeur mesurée. 5. Effectuez la mesure sur la partie médiane de la bande. Valeur normale: ±1.5% Méthode de réglage 1. Lisez la bande étalon (milieu). 2,3. Ajustez la vis de réglage de vitesse VR indiquée fig. 27 pour que la fréquence devienne égale à 3000Hz. Fluctuations de vitesse de défilement Faites les mesures de la même façon que ci-dessus (au début, au milieu et en fin de bande) et déterminez la différence entre les valeurs maximale et minimale, puis calculez comme suit. $\text{Fluctuations de vitesse} = \frac{f_1-f_2}{3000} \times 100(\%)$ f ₁ = valeur maximale f ₂ = valeur minimale Valeur normale: 1%

SECTION	MESURES ET REGLAGES
Ⓓ Réponse en fréquence à la lecture CONDITION * Position lecture Equipement: * Voltmètre électronique * Oscilloscope * Bande étalon...QZZCFM	1. Branchez les appareils de mesure comme pour "l'azimutage de tête", mais en utilisant la bande étalon (QZZCFM) au lieu de la bande étalon d'azimutage (voir fig. 11). 2. Placez l'appareil en position lecture. 3. Lisez la bande étalon de courbe de réponse (QZZCFM). 4. Mesurez les niveaux de sortie à 12.5kHz, 10kHz, 8kHz, 4kHz, 1kHz, 250Hz, 125Hz et 63Hz et comparez chaque niveau de sortie avec celui de la fréquence étalon de 315Hz, sur la borne LINE OUT. 5. Effectuez la mesure sur les deux canaux. 6. Vérifiez que les valeurs mesurées se situent à l'intérieur du gabarit de courbe de réponse.
Ⓔ Gain à la lecture CONDITION * Position lecture Equipement: * Voltmètre électronique * Oscilloscope * Bande étalon...QZZCFM	1. Branchez les appareils comme ci-dessous. (Voir fig. 11). 2. Lisez la partie "niveau standard" de la bande étalon (QZZCFM, 315Hz) et mesurez le niveau de sortie, avec le voltmètre électronique, sur le jack LINE OUT. 3. Effectuez les mesures sur les deux canaux. Valeur normale: Autour de 0.7V Réglage 1. Si la valeur mesurée n'est pas correcte, réglez VR3 (canal gauche) et VR4 (droit) (Voir fig. 27). 2. Après réglage, vérifiez à nouveau la "réponse en fréquence à la lecture".
Ⓕ Fuites de Prémagnétisation CONDITION * Position enregistrement Equipement: * Voltmètre électronique * Oscilloscope	1. Branchez les appareils comme ci-dessous (voir fig. 15). 2. Placez l'appareil en position enregistrement. 3. Réglez les bobines de la trappe L3 (canal gauche) et L4 (droit) pour que la mesure soit au minimum. (Voir fig. 9). 4. Effectuez ce réglage pour les deux canaux.
Ⓖ Courant d'effacement CONDITION * Position enregistrement * Sélecteur de bande ...position Metal ...position CrO ₂ ...position Fe-Cr ...position Normal Equipement: * Voltmètre électronique * Oscilloscope	1. Branchez les appareils comme ci-dessous. (Voir fig. 16). 2. Appuyez sur les boutons d'enregistrement et de pause. 3. Place le sélecteur de bande à la position "Metal". 4. Déterminer le courant d'effacement avec la formule suivante. $\text{Courant d'effacement (A)} = \frac{\text{Tension aux bornes de la résistance R301 (V)}}{1(\Omega)}$ Valeur normale: 110±10mA (position Metal) 5. Si la valeur lue se trouve hors tolérances, régler VR301. 6. Passer sur chaque position du sélecteur de bande. 7. Vérifiez si la valeur mesurée correspond à la norme. Autour de 65mA (position CrO₂) Valeur normale: Autour de 55mA (position Fe-Cr) Autour de 50mA (position Normal)

SECTION	MESURES ET REGLAGES
Ⓗ Courant de Prémagnétisation CONDITION * Position enregistrement * Sélecteur de bande ...position Metal ...position Normal ...position Fe-Cr ...position CrO ₂ Equipement: * Voltmètre électronique * Oscilloscope	A. Mesure et Réglage de la position de la bande 1. Branchez les appareils comme ci-dessous. 2. Appuyez sur les boutons dénégist. 3. Placer le sélecteur de bande à la position "Metal". 4. Lisez la tension sur le voltmètre électronique de prémagnétisation selon la formule. $\text{Courant de prémagnétisation (mA)} = \frac{\text{Tension lue sur voltm. (V)}}{10(\Omega)}$ Valeur normale: 800±20µA 5. Si la valeur lue se trouve hors tolérances, régler VR304 (L-ch), VR304 (R-ch). B. Mesure et Réglage de la position de la bande 1. Changer la sélecteur de bande à la position "Normal". 2. Vérifiez si la valeur mesurée correspond à la norme. Valeur normale: Autour de 300µA 3. Si la valeur lue se trouve hors tolérances, régler VR304 (L-ch), VR304 (R-ch). C. Mesure des positions des bandes au début et à la fin 1. Passer sur chaque position du sélecteur de bande. 2. Vérifiez si la valeur mesurée correspond à la norme. Valeur normale: Autour de 300µA
Ⓖ Indicateur de niveau CONDITION * Position enregistrement * Commande de niveau ...MAX. * Sélecteur de bande ...position Normal Equipement: * Voltmètre électronique * Générateur AF * Atténuateur	1. Branchez les appareils comme sur la fig. 17. 2. Comme il est montré à la fig. 9, le bras de la terre arrête les oscillations instables comprenant Q403 et Q404. 3. Alimenter d'un 1kHz (-24dB) à la fiche de sortie et appuyez sur le bouton d'enregistrement. 4. Régler le ATT de telle façon à ce que la tension de sortie devienne 0.7V (Le niveau est nommé le niveau d'entrée standard). 5. Réglage au "-20dB". A. Réglez l'atténuateur pour que le niveau de sortie devienne 0.7V. B. Réglez VR401 de telle façon que le signal s'allume dans la zone de -20dB±0.2dB (L-ch seulement) (Voir fig. 19). 6. Réglage au "0dB". A. Régler le ATT de telle façon à ce que la tension de sortie devienne 0.7V. B. Réglez VR402 de telle façon que le signal s'allume dans la zone de 0±0.2dB (Voir fig. 20). 7. Répéter deux fois les étapes 5 à 6 ci-dessus. 8. Régler l'ATT et vérifiez si tous les signaux de sortie sont au niveau d'entrée standard (Voir fig. 17).
Ⓖ Circuit Dolby CONDITION * Position enregistrement * Commande de niveau ...MAX.	1. Placez l'appareil en position enregistrement et appuyez sur le bouton d'enregistrement. Réglez le sélecteur de bande à la position "OUT", puis appliquez le signal à l'entrée LINE IN pour obtenir -34.5dB et TP10 (droit).

	MESURES ET REGLAGES
ce à	<ol style="list-style-type: none"> 1. Branchez les appareils de mesure comme pour "l'azimutage de tête", mais en utilisant la bande étalon (QZZCFM) au lieu de la bande étalon d'azimutage (voir fig. 11). 2. Placez l'appareil en position lecture. 3. Lisez la bande étalon de courbe de réponse (QZZCFM). 4. Mesurez les niveaux de sortie à 12.5kHz, 10kHz, 8kHz, 4kHz, 1kHz, 250Hz, 125Hz et 63Hz et comparez chaque niveau de sortie avec celui de la fréquence étalon de 315Hz, sur la borne LINE OUT. 5. Effectuez la mesure sur les deux canaux. 6. Vérifiez que les valeurs mesurées se situent à l'intérieur du gabarit de courbe de réponse.
e FM	<ol style="list-style-type: none"> 1. Branchez les appareils comme ci-dessous. (Voir fig. 11). 2. Lisez la partie "niveau standard" de la bande étalon (QZZCFM, 315Hz) et mesurez le niveau de sortie, avec le voltmètre électronique, sur le jack LINE OUT. 3. Effectuez les mesures sur les deux canaux. <p style="text-align: center;">Valeur normale: Autour de 0.7V</p> <p>Réglage</p> <ol style="list-style-type: none"> 1. Si la valeur mesurée n'est pas correct, réglez VR3 (canal gauche) et VR4 (droit) (Voir fig. 27). 2. Après réglage, vérifiez à nouveau la "réponse en fréquence à la lecture".
nt	<ol style="list-style-type: none"> 1. Branchez les appareils comme ci-dessous (voir fig. 15). 2. Placez l'appareil en position enregistrement. 3. Réglez les bobines de la trappe L3 (canal gauche) et L4 (droit) pour que la mesure soit au minimum. (Voir fig. 9). 4. Effectuez ce réglage pour les deux canaux.
nt nt	<ol style="list-style-type: none"> 1. Branchez les appareils comme ci-dessous. (Voir fig. 16). 2. Appuyez sur les boutons d'enregistrement et de pause. 3. Placez le sélecteur de bande à la position "Metal". 4. Déterminer le courant d'effacement avec la formule suivante. $\text{Courant d'effacement (A)} = \frac{\text{Tension aux bornes de la résistance R301 (V)}}{1(\Omega)}$ <p style="text-align: center;">Valeur normale: 110±10mA (position Metal)</p> <ol style="list-style-type: none"> 5. Si la valeur lue se trouve hors tolérances, réglez VR301. 6. Passer sur chaque position du sélecteur de bande. 7. Vérifiez si la valeur mesurée correspond à la norme. <p style="text-align: center;">Autour de 65mA (position CrO₂) Valeur normale: Autour de 55mA (position Fe-Cr) Autour de 50mA (position Normal)</p>

SECTION	MESURES ET REGLAGES
<p>⊕ Courant de prémagnétisation</p> <p>CONDITION</p> <ul style="list-style-type: none"> * Position enregistrement * Sélecteur de bande <ul style="list-style-type: none"> ...position Metal ...position Normal ...position Fe-Cr ...position CrO₂ <p>Equipement:</p> <ul style="list-style-type: none"> * Voltmètre électronique * Oscilloscope 	<p>Ⓐ. Mesure et Réglage de la position de la bande Metal.</p> <ol style="list-style-type: none"> 1. Branchez les appareils comme ci-dessous (Voir fig. 17). 2. Appuyez sur les boutons d'enregistrement et de pause. 3. Placer le sélecteur de bande à la position "Metal". 4. Lisez la tension sur le voltmètre électronique et calculez le courant de prémagnétisation selon la formule. $\text{Courant de prémagnétisation (A)} = \frac{\text{Tension lue sur voltm. élec. (V)}}{10(\Omega)}$ <p style="text-align: center;">Valeur normale: 800±20µA (position Metal)</p> <ol style="list-style-type: none"> 5. Si la valeur lue se trouve hors tolérances, réglez VR303 (L-ch), VR304 (R-ch). <p>B. Mesure et Réglage de la position de la bande Normal.</p> <ol style="list-style-type: none"> 1. Changer la sélecteur de bande à la position "Normal". 2. Vérifiez si la valeur mesurée correspond à la norme. <p style="text-align: center;">Valeur normale: Autour de 370µA (position Normal)</p> <ol style="list-style-type: none"> 3. Si la valeur lue se trouve hors tolérances, réglez VR302 (L-ch), VR304 (R-ch). <p>C. Mesure des positions des bandes au Fe-Cr et au CrO₂.</p> <ol style="list-style-type: none"> 1. Passer sur chaque position du sélecteur de bande. 2. Vérifiez si la valeur mesurée correspond à la norme. <p style="text-align: center;">Valeur normale: Autour de 390µA (position Fe-Cr) Autour de 500µA (position CrO₂)</p>
<p>Ⓛ Indicateur de niveau</p> <p>CONDITION</p> <ul style="list-style-type: none"> * Position enregistrement * Commande de niveau ...MAX. * Sélecteur de band ...position Normal <p>Equipement:</p> <ul style="list-style-type: none"> * Voltmètre électronique * Générateur AF * Atténuateur 	<ol style="list-style-type: none"> 1. Branchez les appareils comme sur la fig. 22. 2. Comme il est montré à la fig. 9, le branchement de la collecteur de Q403 à la terre arrête les oscillations du multivibrateur instable comprenant Q403 et Q404. 3. Alimenter d'un 1kHz (-24dB) à la fiche "LINE IN", puis pousser le bouton d'enregistrement. 4. Régler le ATT de telle façon à ce que le niveau de sortie à la fiche "LINE OUT" devienne 0.7V (Le niveau d'entrée à cette position est nommé le niveau d'entrée standard). 5. Réglage au "-20dB". <ol style="list-style-type: none"> A. Réglez l'atténuateur pour que le niveau d'entrée soit inférieur de -20dB au niveau étalon d'enregistrement. B. Réglez VR401 de tel façon que le segment de -20dB s'allume dans la zone de -20dB±0.8dB. (L-ch seulement) (Voir fig. 19). 6. Réglage au "0dB". <ol style="list-style-type: none"> A. Régler le ATT de telle façon à ce que le niveau de sortie à la fiche "LINE OUT" devienne 0.7V. B. Réglez VR402 de tel façon que le segment de +1dB s'allume dans la zone de 0±0.2dB du niveau d'entrée standard (Voir fig. 20). 7. Répéter deux fois les étapes 5 à 6 ci-dessus. 8. Réglez l'ATT et vérifiez si tous les segments s'allument quand le niveau d'un signal d'entrée est augmenté de 10dB au dessus du niveau d'entrée standard (Voir fig. 21).
<p>Ⓢ Circuit Dolby</p> <p>CONDITION</p> <ul style="list-style-type: none"> * Position enregistrement * Commande de niveau ...MAX. 	<ol style="list-style-type: none"> 1. Placez l'appareil en position enregistrement et le sélecteur Dolby en position OUT, puis appliquez un signal à 5kHz à l'entrée LINE IN pour obtenir -34.5dB sur TP9 (canal gauche) et TP10 (droit).

SECTION	MESURES ET REGLAGES
<p>Equipement:</p> <ul style="list-style-type: none"> * Voltmètre électronique * Générateur AF * Atténuateur * Oscilloscope 	<ol style="list-style-type: none"> 2. Vérifiez que la valeur en position IN du sélecteur Dolby augmente de 8 (±2.5)dB par rapport à celle obtenue en position OUT.
<p>Ⓢ Gain global</p> <p>CONDITION</p> <ul style="list-style-type: none"> * Positions enregistrement/lecture * Commande de niveau ...MAX. * Niveaux d'entrée normaux MIC -72±4dB LINE IN -24±4dB <p>Equipement:</p> <ul style="list-style-type: none"> * Générateur AF * Voltmètre électronique * Atténuateur * Oscilloscope * Bande étalon vierge QZZCRA pour type de bande normale 	<ol style="list-style-type: none"> 1. Branchez les appareils comme sur la fig. 22. 2. Placez l'appareil en position enregistrement, le sélecteur de bande sur position normale. 3. Appliquez un signal à 1kHz (-24dB) du générateur AF, à travers l'atténuateur, à l'entrée LINE IN. 4. Réglez l'atténuateur pour que le niveau d'écoute simultanée sur LINE OUT soit de 0.7V. 5. Faîtes un enregistrement avec la bande étalon (QZZCRA). 6. Lisez la bande ainsi enregistrée, et vérifiez que la valeur lue sur le voltmètre électronique branché sur LINE OUT est bien de 0.7V. 7. Si la valeur mesurée est différente, réglez VR5 (canal gauche) et VR6 (droit) (voir fig. 27). 8. Recommencez à partir du palier (2).
<p>Ⓢ Courbe de réponse globale</p> <p>CONDITION</p> <ul style="list-style-type: none"> * Positions enregistrement/lecture * Commande de niveau ...MAX. * Sélecteur de bande <ul style="list-style-type: none"> ...position Normal ...position Fe-Cr ...position CrO₂ ...position Metal <p>Equipement:</p> <ul style="list-style-type: none"> * Voltmètre électronique * Générateur AF * Atténuateur * Bande étalon vierge <ul style="list-style-type: none"> ...QZZCRA pour type Normal ...QZZCRY pour Fe-Cr ...QZZCRX pour CrO₂ ...QZZCRZ pour Metal 	<p>Nota:</p> <p>Avant de mesurer et régler, vérifiez que la courbe de réponse en lecture est correct (pour la méthode de mesure, reportez-vous au paragraphe considéré).</p> <ol style="list-style-type: none"> 1. Branchez les appareils de mesure comme sur la fig. 22. 2. Mettre la cassette déssai (QZZCRA) en place dans le support de la cassette. 3. Placez l'appareil en position enregistrement, le sélecteur de bande sur "Normal". 4. Appliquez un signal à 1kHz du générateur AF, à travers l'atténuateur, à l'entrée LINE IN. 5. Réglez l'atténuateur pour que le niveau d'entrée soit inférieur de -20dB au niveau étalon d'enregistrement. 6. A ce moment, le niveau sur LINE OUT est de 0.7V. 7. Enregistrez les fréquences de 30Hz, 70Hz, 200Hz, 1kHz, 4kHz, 8kHz, 10kHz, 12kHz et 13kHz (14kHz pour bande Fe-Cr/ bande CrO₂, 15kHz pour bande Metal) à niveau constant. 8. Lisez cet enregistrement et exprimez en dB les différences entre le niveau de sortie de chaque fréquence et le niveau à 1kHz. 9. S'assurer que la valeur mesurée se trouve dans la plage spécifiée dans le diagramme de la réponse en fréquences totale pour les bande Normal montre dans les fig. 23. 10. Si la valeur lue se trouve hors tolérances, réglez VR302 (L-ch), VR304 (R-ch). <p>Nota:</p> <ul style="list-style-type: none"> • Le réglage normal du canal gauche se fait en utilisant VR302. Pour régler davantage le canal gauche, utiliser VR303. • Lorsque la réponse en fréquence entre la plage des fréquences moyennes et des fréquences élevées devient supérieure à la valeur standard, comme montré par la ligne continue dans la fig. 26, se référer au réglage du courant de polarisation. • Pour la mesure du courant de prémagnétisation, reportez-vous au paragraphe correspondant. <ol style="list-style-type: none"> 11. Recommencez à partir du palier 2. 12. Changer la bande déssai sur Fe-Cr (QZZCRY), CrO₂ (QZZCRX), Metal (QZZCRZ). 13. Passer sur chaque position du sélecteur de bande. 14. Effectuer la mesure de la même manière que ci-dessus. 15. S'assurer que la valeur mesurée se trouve dans la plage spécifiée dans le diagramme de la réponse en fréquences totale pour les bandes Fe-Cr, CrO₂ et Metal montré dans les fig. 24 et 25.

SERVICE NEWS

**NPS National Panasonic
Service GmbH**

An alle NPS-Filialen
Kundendienstzentralen
Autorisierten Fachhändler
EK, VK, QC, Techn. Klarstellung
Service Berater, Schulungsleiter

Nr.: 229	Datum: 28. März 1983 Herr Platzek, NPS-Mü/MH 13/83
THEMA	TEXT
RS-M 24	Betreff: Friktion der RS-M 24 Mechanik ist geändert worden.
Bandzug = 60 gr/cm	Symptom: Bandzug (Torque) zu hoch. Bei Bandzügen über 60 gr/cm kann es zur mechanischen Beschädigung des Bandanfanges kommen.
QZK 0241	Abhilfe: Nur noch die Friktion Take up gear assy QZK 0241 bestellen (= 55 gr/cm) und verwenden.
	NPS-HH W. Klingler